

Owner's Operation Manual



TABLE OF CONTENTS

TABLE OF CONTENTS.....	2
INTRODUCTION.....	3
ELECTRICAL SPECIFICATIONS	4
WORKSPACE REQUIREMENTS.....	5
ENVIRONMENT CONDITIONS.....	6
UNPACKING, SET-UP AND INSTALLATION.....	7, 8
IMPORTANT SAFEGUARDS.....	9
SAFETY FEATURES.....	10
LAMINATOR FEATURES.....	11
FRONT CONTROL PANEL.....	12
BACK CONTROL PANEL.....	13
CLUTCH CONTROL PANEL.....	14
TOP MOTOR CONTROL PANELS	15
CHECKING OPERATION.....	16
SET-UP AND OPERATION.....	17
LOADING ROLLS OF MATERIAL.....	18
TABLE OPERATION	19
UNWIND BRAKE / COOLING SYSTEM OPERATION.....	20
AUTO-RUN / FOOTSWITCH OPERATION	21
FEEDING IMAGES / ROLL EASEL USE.....	22
WEBBING FILMS WITHOUT A RELEASE LINER.....	23
WEBBING FILMS WITH A RELEASE LINER.....	24
DECALING (HEAT-ACTIVATED).....	25
DECALING (PRESSURE-SENSITIVE)	26
MOUNTING	27
ENCAPSULATING.....	28
PRE-COATING BOARDS.....	29
LOW-TEMP VINYL TRANSFER.....	30
PROCESS CONTROL SHEET	31
CLEANING / MAINTAINING YOUR LAMINATOR.....	32
PERIODIC MAINTENANCE SHEET	33
TROUBLE SHOOTING GUIDE.....	34
ERROR CODES.....	35
GLOSSARY OF TERMS	36
SPARE PARTS LIST.....	37
TECHNICAL SPECIFICATIONS.....	38
LIMITED WARRANTY	39

INTRODUCTION

Thank you for purchasing a SEAL® Image® 6500 Laminator. We have designed the SEAL Image 6500 to give you years of reliable service. As you become familiar with the your laminator, you will appreciate the high quality of its production and the excellence in its engineering design.

The Image 6500 is a true bi-directional laminator. Designed for full range, high volume requirements including heat or pressure sensitive lamination, encapsulation and hot or cold mounting of images. The two sets of symmetrical bi-directional rollers speed production, running heat-activated materials from the front and cold pressure-sensitive applications from the back.

By following the guidelines for proper care and use of the SEAL Image 6500, you can depend on many years of trouble-free profitability from your investment.

The purpose of this manual is to outline the materials and process when using SEAL® Brands supplies with your laminator to create signs, displays, and flexible graphics with professional results. The manual includes instructions of various laminating procedures, which are meant to give you comprehensive information needed for the efficient use of your laminator.

Please read and fully understand the entire manual before proceeding to use your laminator.

STATEMENT OF INTENDED USE

Your SEAL Image 6500 Laminator meets the CE Machinery Safety Directive (89/392/EEC, including 91/368/EEC, 93/44/EEC and 93/68/EEC) and is cETL listed (UL775, 1950/EN60950).

The SEAL Image 6500 laminator has been designed to be used with SEAL Brands materials. When used with these products, you are able to mount, mount and laminate, and encapsulate prints in one step. Your laminator has been tested with SEAL Brands supplies and we recommend using these products for professional results.

WARNING! This laminator is designed for mounting and laminating. Any use other than the intended may cause damage to the laminator or physical harm to the user.

LIABILITY STATEMENT

The details given in this manual are based on the most recent information available to us. They may be subject to change in the future. We retain the right to make changes to the construction or the design of our products without accepting any responsibility for modifying earlier versions previously delivered.

CAUTION! Please pay attention to all passages marked this way. This information is vital to preventing user injury and/or damage to the unit. Failure to follow this information could void the user's warranties and transfer all safety obligations to the user.

ELECTRICAL SPECIFICATIONS

Connect the laminator in accordance with the details given on the identification plate attached to the rear of the laminator. Refer also to the Technical Specifications page for more information.

**Single Phase Version:
(Part No. 60424)**

For areas where the voltage requirements are 200-240V, the following is applicable:

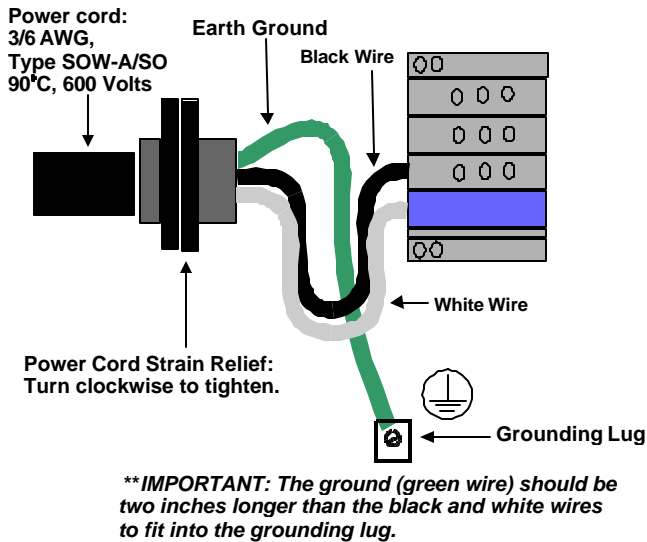

Figure 1. Wiring Diagram

CONNECTING YOUR LAMINATOR

All domestic laminators will be shipped without a power cord. It is required that only a qualified electrician provides power to the laminator or the warranty will be void. We recommend a Ground Fault Interrupter (GFI) circuit breaker with a 60-amp load rating, not exceeding a 100-amp load rating. Use 3/6 AWG power cord, Type SOW-A/SO rated to 90° C and 600 Volts. See Figure 1 Wiring Diagram for detailed information. For European laminators use a Residual Current Device (RCD/RCCD). Once power is connected to your laminator, press the Stand-by switch UP on the front control panel to turn the laminator ON. If you have no display, refer to the “Troubleshooting” page for problem solving information.

WARNING! Any unauthorized changes or modifications to this unit without our prior written approval will void the user’s warranty and will transfer health and safety obligations to the user.

IMPORTANT! SEAL Graphics recommends that a licensed electrician in accordance with electrical codes in your area install your mains power. Specifications subject to change without notice.

IMPORTANT! The mains outlet should be fused no higher than 60 Amp, Three-phase -or- 100 Amp, Single phase.

WORKSPACE REQUIREMENTS

- Keep the area around your laminator clear with adequate space around it so you can feed, receive and trim mounted and/or laminated images.
- An area 15' x 11' (4.5m x 3.4m) is the smallest area recommended. We recommend a room size of 20' x 18' (6.1m x 5.49m) to accommodate a laminator and 2 (4' x 8') tables on castors for finishing/layout work. This area is required for loading and unloading rolls of material onto the unwind shafts and feeding and receiving the maximum mounting board lengths into the laminator correctly.

NOTE: Maximum board lengths are up to 12 feet long.

- The work area should be level, flat, and well lit.

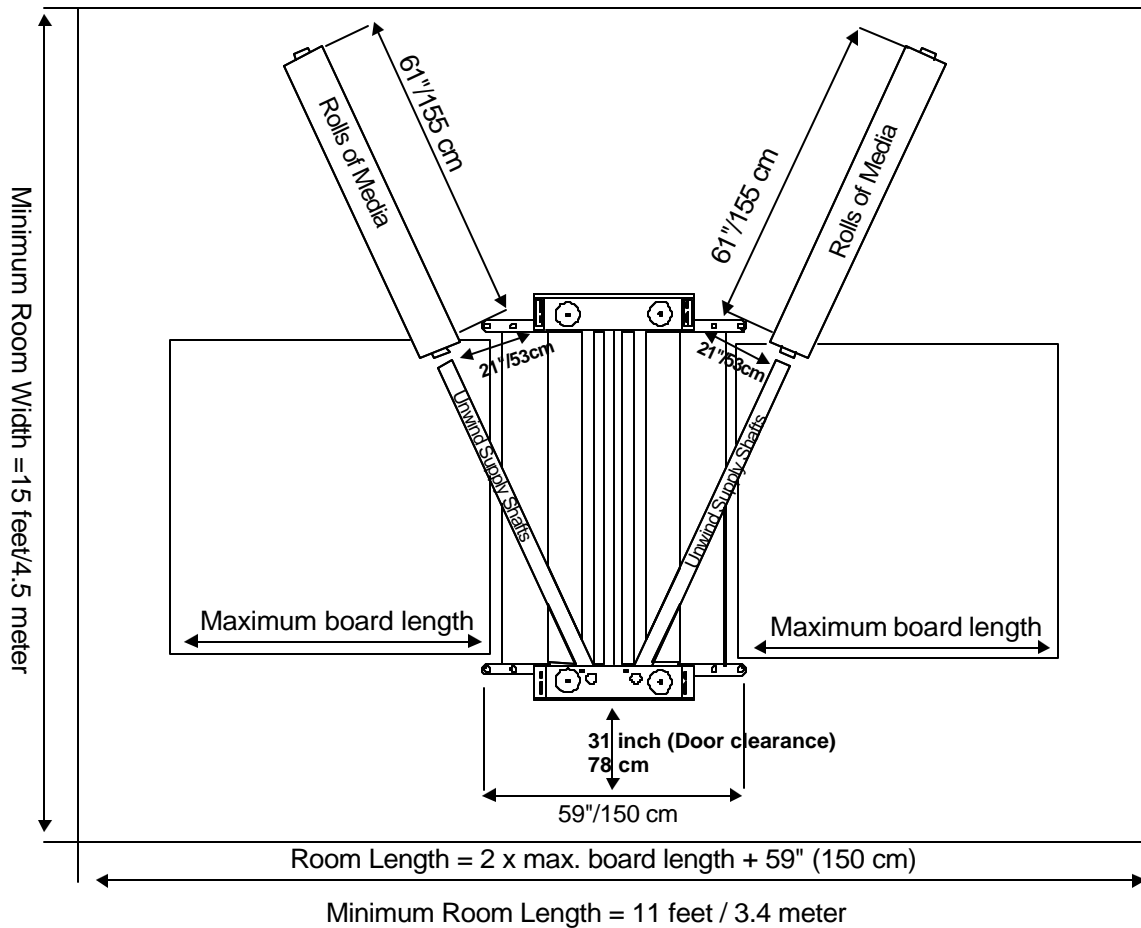

Figure 2. Workspace Area Diagram

ENVIRONMENT CONDITIONS

The following environmental conditions are ideal for the best operation of the laminator.

AMBIENT TEMPERATURE

The best temperature for the SEAL[®] Image[®] 6500 is between 50°F and 86°F (16°C and 30°C).

Do not expose the laminator to direct sunlight as output quality may be affected.

RELATIVE HUMIDITY

For best results, the ambient relative humidity for the SEAL Image6500 should be between 70-90% non-condensing. Too much humidity will affect the prints being laminated causing problems with film adhesion.

WATER AND MOISTURE

If the laminator is installed in a damp room or near water, the electrical power supply must be in accordance with the standards prevailing in the country concerned.

SURROUNDINGS

Install the laminator in surroundings that are as clean and dust free as possible in order to obtain the highest quality output.

The background dust level must not exceed that found in a typical office/computer room environment.

The materials that are used on this laminator can have an electrostatic charge and will attract dust, adversely affecting the output.

POWER SUPPLY

Connect the laminator in accordance with the details given on the identification plate attached to the rear of the laminator. Refer also to the Technical Specifications page for more information.

UNPACKING, SET-UP AND INSTALLATION

Only skilled personnel should perform installation. Read and comply with all warnings and follow the proper installation procedures and safety guidelines.

- Refer to outside of crate for Uncrating/Recrating instructions.
- Take into account the weight of the laminator (2260-lb./1025 kg net weight) when moving. Use equipment with which the weight can be safely lifted. The laminator is transported on a wooden pallet (skid). If your laminator is still on its skid, you can move it with a forklift to put it near its place of use.

IMPORTANT! Set the forks of the forklift to the maximum lifting width of the laminator, so the laminator's center of gravity is central between the forks.

- NOTE: We recommend that you save the transport bolts, nuts and plates of the shipping crate for any major moves that you plan to make with the laminator in the future.
- Remove the transport bolts from the skid's transport plates with a ½" open-end wrench or adjustable wrench. Using the wrench on the bolt's flat, back the bolt up into the cabinet enough to clear the cabinet castors for ease in moving.
- Your laminator has castors to allow for easy moving. Roll the laminator to the location it will be used. (See Workspace Area Diagram – Figure 2).
- Lock the castors once it is in place and remember to unlock them before moving the laminator again.

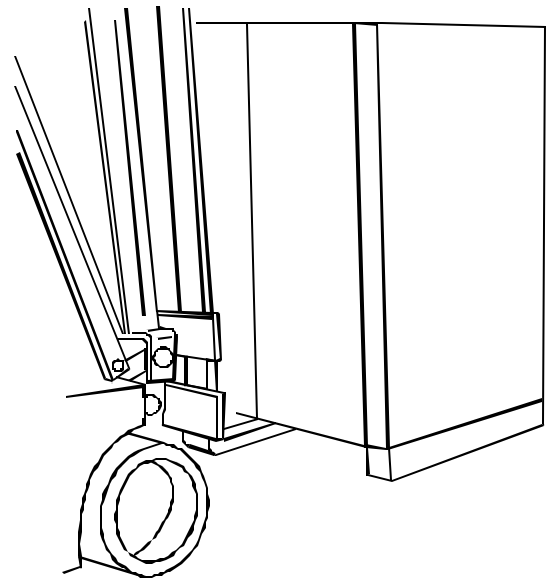

Figure 3. Moving the laminator with a forklift

Accessories Included:

- 4 Foot Levelers
- 1/2" Wrench
- 3/16" Allen Wrench
- Grease Gun Kit
- Spare Fuses (Inside cabinet)
- Tape Measure
- Snitty® Safety Knife
- Image Roll Cleaner
- Terry Cloth Towel
- Spare Core for Wind-up Shafts
- Owner's Manual
- Installation Instruction Sheet

UNPACKING, SET-UP AND INSTALLATION

UNPACKING YOUR LAMINATOR

- Remove the transport packing and the plastic shrink-wrap the laminator is wrapped in to avoid moisture penetration.
- Remove the accessory kit package from the top of the laminator, which includes the necessary tools for installation.
- Remove the footswitches from the top of the laminator and remove the foam wrapped around them. Place a footswitch on each side of the laminator for operator use while feeding images.
- Remove the front and back tables (in cardboard boxes) from the top of the laminator. Remove the tables from the cardboard boxes and set them aside.
- Remove the protective foam wrapped around the front and back table arms.
- Follow the Installation Instruction sheet in the accessory pack to reattach the table arms.
- Once reattached, insert the tables into position.
- Remove the roll easel shaft from the crate and remove the packing wrap.
- Place the roll easel shaft into the table receivers and lock into place.
- The top rollers will go up automatically when air is connected.
- Remove the foam placed between the top and bottom rollers.
- Remove the stickers securing the protective paper on the rolls using your fingers only.
- Then gently pull the paper towards you to unwind off the roll.

WARNING! DO NOT USE OPEN BLADES TO REMOVE THE PROTECTIVE PAPER ON THE ROLLERS.

- Roller damage caused by improper use of cutting tools will void the user's warranty. Small cuts and imperfections in the rollers greatly affect the quality of the output and roller replacement costs are expensive.

LEVELING YOUR LAMINATOR

- Thread the leveling feet included in the accessory pack onto each of the four transport bolts located in the corners of the cabinets. Tighten securely.
- Use the ½" wrench to turn the transport bolts down until the leveling feet are positioned flat against the floor.
- Insert a 3' x 1' (91cm x 30cm) piece of foam board across the two center chill idlers and place the level in the center on top of this foam board.
- Adjust the leveling feet for each side cabinet until level.
- Next, place the level on the tops of each of the cabinets lengthwise and adjust the leveling feet from the front to the rear of the cabinet as needed.

IMPORTANT SAFEGUARDS

SAFETY SYMBOLS USED ON THE LAMINATOR

IMPORTANT! Read and make sure you understand these safety and operating guidelines.

Rotating Parts: Risk Of Injury



CAUTION! Failure to use caution near rotating rollers could result in physical injury. Be careful that items such as loose clothing, long hair and jewelry do not become entangled in rotating parts.

The laminator is equipped with photoelectric eyes to prevent contact with the rotating rollers. Make sure that these safety provisions are always in operation/installed.

IMPORTANT! The laminator operation will cease immediately when the photo electric eyes, set directly in the path of the front of the rollers, are blocked. On Domestic version laminators, the foot switch overrides the photoelectric eyes. When the photo eye is blocked, a BUZZER sounds, warning of close proximity to the nip. Use care to keep hands clear of the rollers while using the foot switch to prevent possible injury.

Hot Surface: Risk Of Injury On Contact



CAUTION! The laminator contains a heated top roller, which may reach temperatures of 250°F (121°C). There is a danger of burns if the heated top roller is touched during use. Even after switching off the laminator, the roller remains hot for a long time.

Electrical Parts – Danger of being injured by electricity



WARNING! Do not open the locked cabinet doors because of the risk of being injured by voltage. Only authorized maintenance and service technicians or safety personnel should have access to the keys for mechanical upkeep or repair.

WARNING! Make sure the door interlock on the left side cabinet is disengaged when opening the right side cabinet door for any maintenance. The door interlock automatically shuts the laminator power off when the door is opened.

IMPORTANT! Do not place heavy objects on the power supply cord.

PREVENTATIVE MEASURES

Do not feed objects such as staples, paper clips and rough or abrasive materials through the laminating rollers.

Keep all objects, such as tools, rulers, pens, markers or knives away from the roller opening. Refrain from leaving such items on the front table to prevent them from accidentally being fed into the rollers.

IMPORTANT! NEVER cut or slice directly on the rollers as any cuts or gouges will destroy them. ALWAYS use cutters with enclosed blades to prevent cutting the rollers and to avoid extensive replacement costs.

WARNING! Always adjust the shim wheels to create a gap between the laminating rollers to prevent flat spots from developing when the laminator is not in use. Flat spots will affect the quality of the output and void the warranty replacement.

IMPORTANT! The main rollers should be together and turning while heating up to prevent uneven hot spots on the roller. A stationary roller will develop concentrated heat in one area, which will damage the roller. Pull the front table away from the heated roller when not in use to prevent possible warping.

SERVICING AND REPLACEMENT PARTS

Service and maintenance must be performed fully in accordance with the instructions. Servicing by any unauthorized technician voids the warranty. The service technician must use replacement parts specified by SEAL® Graphics.

Service Technicians must perform safety checks after completing any service or repairs to the laminator.

SAFETY FEATURES

The SEAL[®] Image[®] 6500 Laminator is designed with safety and protective devices with the user's safety of utmost consideration. However, following safe operating guidelines is still the responsibility of the operator.

Hand-Operated Emergency Stop Buttons

Emergency Stop buttons are located on each side of the cabinets for easy access. Once pressed, they immediately cease the laminator's operation and raise the rollers. Use these only in the case of an emergency or you may damage an image during a process.

NOTE: Once pressed, these buttons lock and must be turned clockwise to reset.

After resetting the Emergency Stop button, you must turn the heaters back on (if being used), and push one of the Motor Direction Switches to begin processing again.

Foot-Operated Emergency Tap Switches

Located on both sides of the laminator, pressing on these tap switches will immediately cease the laminator's operation and raise the rollers.

Covered Foot Switches

One on each side of the laminator allows for complete user control when initially feeding an image into the nip or for feeding a delicate image through the rollers. The cover prevents accidentally stepping on the foot switch and starting the laminator.

WARNING! The laminator operation will cease immediately when the photo electric eyes, set directly in the path of the front of the rollers, are blocked. On Domestic version laminators, the foot switch overrides the photoelectric eyes. When the photo eye is blocked, a BUZZER sounds, warning of close proximity to the nip. When the photo eye is blocked, the laminator runs in slow mode at a speed of 2.0 ft (0.6m) per minute. Use care to keep hands clear of the rollers while using the foot switch to prevent possible injury.

Photo Electric Safety Eyes

A light beam path set directly in front and back of the laminating roller openings prevents foreign objects from passing between the rollers. (The eyes are set for use at the factory and checked by the service representative.)

Locking Cabinets

The cabinets that house the inner workings of the laminator include locks that maintenance or safety personnel can open only with the supplied keys.

WARNING! Use of the inside of the cabinets for storage may cause possible personal injury and/or damage to the inner workings and will void the warranty.

Door Interlock

Located on the left side cabinet (facing front of laminator), it automatically shuts the laminator power off when the door interlock switch is turned to the OFF position.

WARNING! For any servicing, ALWAYS turn the door interlock switch to the OFF position and the main power circuit breaker off before opening the side cabinets.

LAMINATOR FEATURES

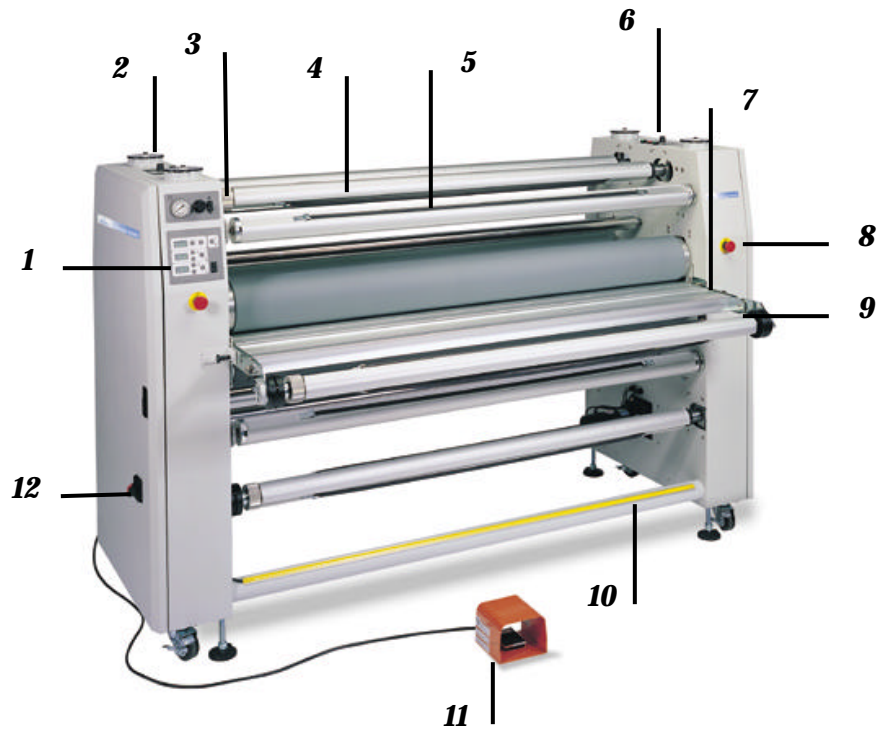

Figure 4
Laminator Features

1. Control panel system

- For independent control of pressure, temperature and read-out of speed and material usage.

2. Shim Wheels (4)

- Dial-in roller height adjustment for fast and accurate roller nip setting, which adjusts for the thickness of the material to be processed

3. Integral Braking System

- A simple braking system with a knurled collar provides the means of adjusting the brake tension for the films and images. Fitted on both roll easel shaft and the four unwind shafts.

4. Swing-Out Autogrip Unwind Shafts (4)

- Easy loading and positioning of materials. No need for manual locking keys. Suitable for rolls wound onto a 3" ID core.

5. Autogrip Wind-up Idlers (4)

- Removable shafts for winding up the release liner, finished images or other laminate material. Use with 3" ID spare cores.

6. Top Motor Control Panels

- Controls in-feed direction and processing speed from all four corners.

7. Interchangeable In-feed Tables (For North America)

- User preference for flat table with image guide or print guide table, interchangeable from front to rear of laminator. For ROW the laminator is equipped with flat tables, front and back.

8. Emergency Stop Buttons (4)

- Immediately ceases the laminator's operation and raises the rollers.

9. Autogrip Roll Easel Shaft

- Removable media unwind shaft for images on a roll. Allows for roll-to-roll laminating in continuous operation when used with the wind-up idler. Interchangeable from front to rear of laminator.

10. Foot-operated Emergency Tap Switches (2)

- (Auxiliary Stop) Immediately ceases the laminator's operation and raises the rollers.

11. Covered Foot Switches (2)

- Allows for complete user control when initially feeding in an image.

12. Door Interlock

- Automatically shuts the laminator power off when the Door Interlock switch is turned to the Off position.

** Bi-Directional Operation

- Eliminates the need for cool-down allowing quick application changeovers.

** Dual-Position Cooling Tube

- Offers quick and uniform cooling for smooth, flat output during heat-activated processes. Can be positioned above or below the chill idlers and can be rotated to direct airflow as desired.

** Drive System

- Heavy-duty Clutch and simplified drive system – Provides smoother performance at all speeds and different film thickness.

** Heating Elements

- Electric High-Wattage Heating Elements and Temperature Controls with Infrared Temperature Sensors – Provide for rapid, even heating to 275° F (135°C) and maximum accuracy.

FRONT CONTROL PANEL

1. **Air Pressure Gauge:** Indicates the PSI reading for the downward pressure of the top main roller. The standard setting for the normal operation is 35-55 PSI.
2. **Air Regulator Knob:** Adjusts the downward pressure of the top roller. Turn clockwise to increase the pressure.
3. **Roller Up/Down Switch (Front, Top):** Press up to raise the roller. Press down to lower the roller.
4. **Cooling Fan On/Off Button:** Turns On/Off the cooling fan. The corresponding LED will be lit when the fan is ON.
5. **Reset Button:** Press this button to reset the material total usage counter to zero. Totalizer Display must be showing to be able to zero out.
6. **Ratemeter /Totalizer Button:** Pressing this button will toggle between the roller speed readout or total material usage. Press this button to track and display the total number of feet or meters run in a given period, which can help to monitor film usage. The total will be stored even after the laminator is turned off, and adds to the total whenever the bottom main roller is turning. The corresponding LED will be lit when the totalizer is being used.
7. **Ratemeter/Totalizer Readout:** Displays the rate of speed of the main rollers in either feet or meters per minute, or displays the total number of feet or meters run in a given period.
8. **Top Roller Temperature Increase Button:** Press this button once to view the temperature set point. Press and hold the button to raise the top roller temperature.
9. **Top Roller Temperature Readout:** Displays both the set and actual temperature of the top roller.
10. **Top Roller Temperature Decrease Button:** Press this button once to view the temperature set point. Press and hold the button to lower the top roller temperature.
11. **Bottom Roller Temperature Increase Button:** Press this button once to view the temperature set point. Press and hold the button to raise the bottom roller temperature.
12. **Bottom Roller Temperature Readout:** Displays both the set and actual temperature of the bottom roller.
13. **Bottom Roller Temperature Decrease Button:** Press this button once to view the temperature set point. Press and hold the button to lower the bottom roller temperature.
14. **Bottom Roller Temperature On/Off Button:** Turns On/Off the bottom roller heater. The corresponding LED will be lit when the heater is ON.
15. **Top Roller Temperature On/Off Button:** Turns On/Off the top roller heater. The corresponding LED will be lit when the heater is ON.
16. **Stand-by On/Off Switch:** Press this switch up to turn on the laminator. Press this switch down to put it on Standby. In Standby, the laminator power is still on, but all functions are disabled.

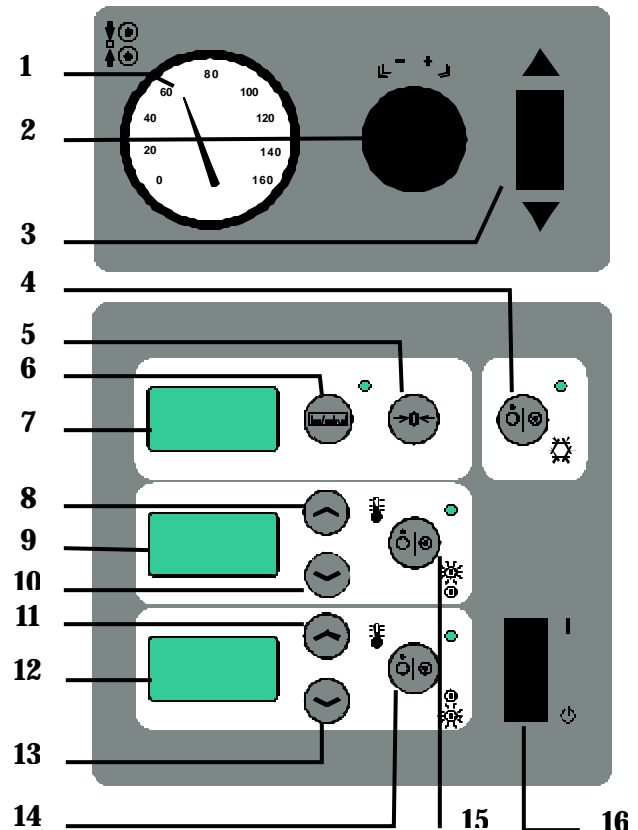

Figure 5. Front Control Panel

BACK CONTROL PANEL

1. Air Pressure Gauge: Indicates the PSI reading for the downward pressure of the top pull roller. The standard setting for the normal operation is 35-55 PSI.
2. Air Regulator Knob: Adjusts the downward pressure of the top pull roller. Turn clockwise to increase the pressure.
3. Roller Up/Down Switch (Rear, Top): Press the switch up to raise the roller. Press the switch down to lower the roller.
4. Reset Button: Press this button to reset the material total usage counter to zero. Totalizer Display must be showing to be able to zero out.
5. Ratemeter /Totalizer Button: Pressing this button will toggle between the roller speed readout or total material usage. Press this button to track and display the total number of feet or meters run in a given period, which can help to monitor film usage. The total will be stored even after the laminator is turned off, and adds to the total whenever the bottom main roller is turning. The corresponding LED will be lit when the totalizer is being used.
6. Ratemeter/Totalizer Readout: Displays the rate of speed of the main rollers in either feet or meters per minute, or displays the total number of feet or meters run in a given period.

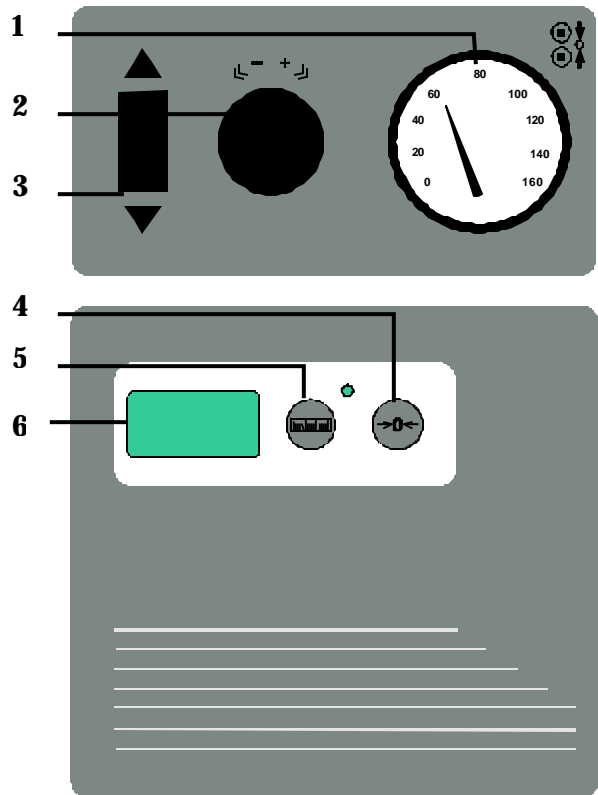

Figure 6. Back Control Panel

CLUTCH CONTROL PANEL

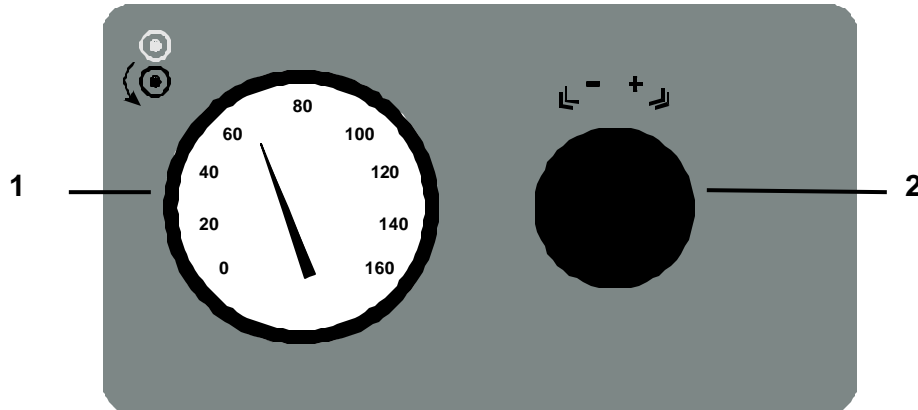

Figure 7. Clutch Control Panel

- The Clutch Control Panel is located on the left side cabinet when facing the rear of the laminator.
- The operator can adjust the amount of tension that is directly applied to the laminate between the main and pull rollers.
- The amount of tension applied affects the output and extreme pull tension will stretch the hot films causing outfeed waves in the finished product. This is a factor with films such as Print Guard®, which stretches easily.
- Excessive tension will also cause downward curl in the finished product.
- The standard setting for normal operation is 40-60 PSI.

1. AIR PRESSURE GAUGE

Indicates the PSI reading for the pulling tension of the bottom pull roller. The standard setting for normal operation is 40-60 PSI.

2. AIR REGULATOR KNOB

This knob adjusts the pulling tension of the bottom pull roller. Pull out the knob and turn to adjust; push back in to set. Turn clockwise to increase the amount of pull tension and turn counter-clockwise to decrease the amount.

IMPORTANT! Excessive pull clutch tension will cause premature wear to the drive system and may cause damage to the laminator. Use the minimum amount required for the laminating process.

TOP MOTOR CONTROL PANELS

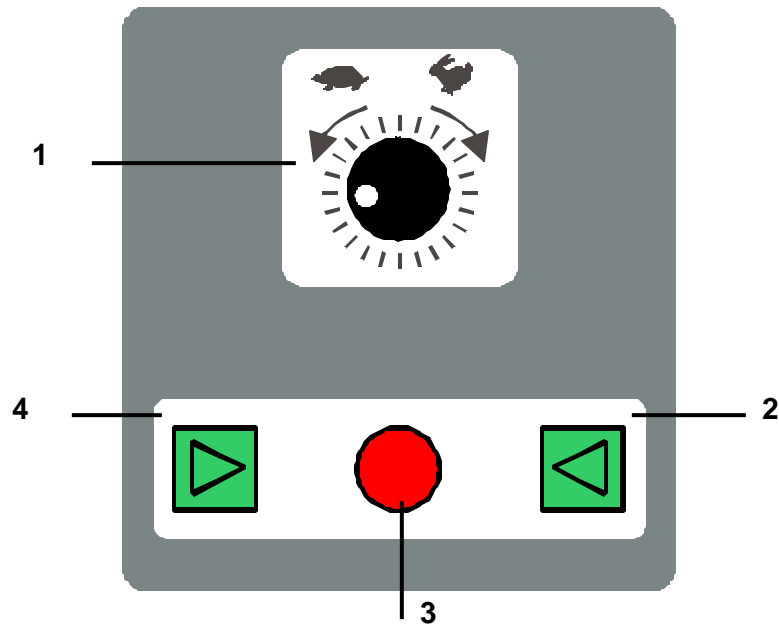

Figure 8. Top Motor Control Panel

MOTOR CONTROL PANEL OPERATION

- The Motor Control Panels are centrally located on the top of both side cabinets.
- This location provides easy access from all sides of the laminator.
- Right or left-handed operators can use either panel to make speed or direction processing adjustments from the front or rear of the laminator.
- A change made to either panel affects the settings of both panels.

3. Speed Adjustment Knob

Use this knob to adjust the speed of the roller rotation. Turn the knob clockwise to increase the speed of the roller rotation and counter-clockwise to decrease the speed. The speed of the rollers is continuously adjustable between 0 and 15 ft /min. (0 and 4.5m/min.). The roller speed can be viewed in the top display readouts on both the front and back control panels.

4. Reverse Roller Direction Switch

Pressing this switch runs the rollers in the reverse direction when standing at the front of the laminator. This direction will be used when processing cold pressure-sensitive films from the rear of the laminator through the pull rollers.

5. Motor Stop Switch

Pressing this switch stops the roller rotation.

NOTE: You must press this switch before you can press the opposite direction switch.

6. Forward Roller Direction Switch

Pressing this switch runs the rollers in the forward direction when standing at the front of the laminator.

CHECKING OPERATION

After you are familiar with the control panels and their functions, check all operations.

CHECK THE MAIN POWER

- Press the Stand-by switch up and the front and back displays on the control panels should be lit.
- The center red switch on both top cabinet control panels should be illuminated.

CHECK THE EMERGENCY STOP BUTTONS

- Press one of the Emergency Stop Buttons and the laminator will shut down.
- Rotate the Emergency Stop Button clockwise to reset.
- Repeat this procedure with all four Emergency Stop Buttons.

CHECK THE HEATER CONTROLS

- Press the Top Heater On/Off button once; the corresponding LED should be lit.
- The readout will display the ambient temperature.
- Press and hold the top heater Up Arrow to increase the temperature set point. Watch the readout for 5 minutes to verify that the temperature increases.
- Press and hold the Down Arrow to decrease the temperature set point.
- Press the top heater On/Off button again once; the corresponding LED should not be lit.
- Repeat this procedure for the Bottom Heater.

CHECK THE MOTOR AND FOOTSWITCHES

Check both motor control panels as follows:

- Push the green Motor Forward Switch and the rollers should rotate in the forward direction.
- Press the green Motor Reverse Switch and the rollers should rotate in the reverse direction.
- As you turn the speed control knob clockwise the speed of the rollers should increase and the speed readout (top display on front and rear control panels) should increase in number.
- Turning the speed control knob counter-clockwise should decrease the speed of the rollers and the speed readouts should decrease in number.
- Press the center red Motor Stop Switch and the rollers should stop rotating.
- Press the footswitch and the rollers should rotate in whichever roller direction that was last pressed. Check both footswitches for operation.

CHECKING THE ROLLERS

Your laminator has pneumatic pressure adjustment with fine-tune control for a smooth, flat finish. Correct adjustment of the pressure rollers' height is essential for safe and proper operation. Check this prior to every use.

Check the vertical movement of the top rollers as follows:

- Press the Roller switch UP. The top roller should rise smoothly and evenly on both ends.
- Press the Roller switch DOWN. The top roller should lower smoothly and evenly on both ends.
- Repeat this procedure for both front and back top rollers.

IMPORTANT! The silicone covering of the rollers is soft. Do not scratch the surface with a sharp object or fingernail.

WARNING! If your laminator does not operate correctly, contact Technical Service immediately.

SET-UP AND OPERATION

TEMPERATURE SETTINGS

- Select the film(s) that you will use on the top (and bottom) of the images.
- Check which temperature setting is recommended for your SEAL® Brands material (see literature enclosed in your material box).
- Refer to the Control Panel Diagrams for information on setting the temperature.

NOTE: If a process requires heat, turn ON the heaters approximately 45 minutes before use to ensure that the rollers are at the correct operating temperature.

IMPORTANT! The main roller should be down and turning to prevent uneven hot spots on the roller. A stationary heated roller will develop concentrated heat in one area, which will damage the roller.

SHIM WHEEL SETTINGS

Whenever you mount onto a board, etc., it is important to adjust the rollers to create a gap nearly equal to the thickness of the board being used. This is done so that anything passing between the rollers will receive the right amount of pressure.

Equivalent Press Measurements

Inches	Metric (mm)	Decimal
1	25 mm	1.000
3/4	19 mm	0.75
1/2	13 mm	0.50
3/8	10 mm	0.375
1/4	6 mm	0.25
3/16	5 mm	0.1825
1/8	3 mm	0.125
1/16	2 mm	0.0625
-1/16	-2 mm	-0.0625
0	0	0

HOW TO SET THE SHIM WHEELS

- First, determine the thickness of the board that you will use for mounting.
- You must first raise the rollers and then turn the shim wheels until the desired measurement corresponds with the thickness of board being used.

WARNING! Too much pressure can crush the board being used and even damage the top and bottom rollers. Normally, a press of .025" (0.6mm) is sufficient.

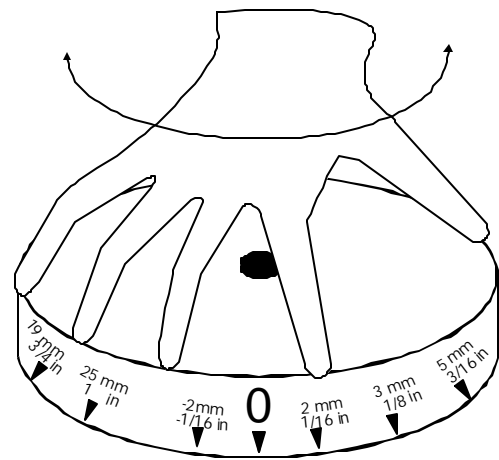

Figure 9. Shim Wheel Adjustment

LOADING ROLLS OF MATERIAL

LOADING A ROLL OF MATERIAL

- Turn the unwind brake fully towards you so there is no brake tension on the unwind shaft- (until no gap is visible between the unwind brake and the lock collar).
- Swing out the desired unwind shaft towards you and slide a roll of material onto the unwind shaft. Ensure that the rubber blocking cords are on the top and bottom of the shaft for easy loading (see below).

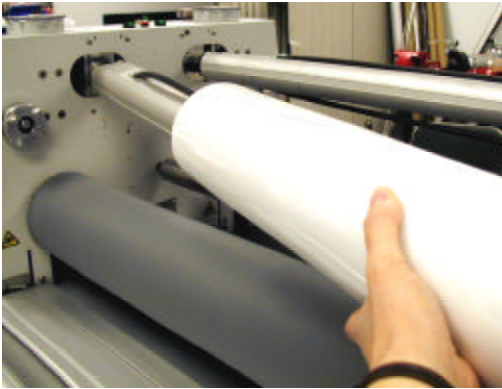

Figure 10. Loading Roll of Material

- For the bottom unwind shafts rotate the outer section of the locking receiver towards you to open the receiver so the shaft can be pulled out and loaded with material (see Figure 11).

IMPORTANT! Make certain that you place the roll of film on the unwind shaft so that the material will feed with the adhesive side facing away from the rollers.

IMPORTANT! Swing the unwind shaft in towards the receiver making sure to align the cutout notch in the end of the unwind shaft with the receiver notch. Press the unwind shafts firmly into the receivers to prevent tension and tracking problems.

NOTE! If the end of the shaft is not correctly aligned you will not be able to adjust the brake tension properly, causing tracking problems and possibly damaging the end of the shaft.



Figure 11. Locking Receiver

- Remember to lock the receiver on the bottom unwind shaft so the film tracks correctly and the unwind shaft does not pull out of the receiver.
- Center the films on the unwind shafts using the rulers on the unwind shafts for alignment.

IMPORTANT! The position of all films, boards, rolls of media and cardboard cores for wind-ups must be set central in the laminator to ensure optimum quality and correct tracking.

- For alignment accuracy, pull a length of film forward off the top unwind shaft until it drapes over the film on the bottom unwind shaft. Make sure the edges of both film rolls line up.
- Now secure the rolls of material onto the shafts by gripping the shafts with one hand while rotating the rolls of material with the other hand in the direction it will be pulled off the unwind shafts. The rubber blocking cords will catch on the inside of the material core and hold the material secure on the shaft.
- If material needs to be rotated, turn the shafts, not the rolls of film otherwise the roll of film will no longer be secure to the shaft.

UNWIND SHAFT CORD ADJUSTMENT

NOTE! Over time the rubber blocking cords will stretch and need to be shortened slightly. To adjust the cord, unfasten the cord at one end and cut off .39" (1 cm). Re-fasten the cord under the cord retainer clip.

TABLE OPERATION

PIVOTING TABLE USE FOR WEBBING

- First, remove the roll easel shaft from its brackets and set aside.
- Pull out both retaining plungers of the roll easel brackets and pivot the brackets down and forward as shown in Figure 12.



Figure 12. Pivoting Roll Easel Bracket Down

- Remove the top and bottom wind-up idlers for easy webbing and set them aside.
- On the right-hand side of the table, pull out the locking retaining plunger and turn sideways to lock with plunger recessed (see Figure 13).
- Move to the left side and pull out the non-locking retaining plunger on the left-hand side of the table.
- Allow the table brackets to slide outwards and down.
- Grasp the front edge of the table and lifting up pivot the table towards you, away from the rollers (see Figure 13).



Figure 13. Releasing Retaining Plunger

- Reach through the opening between the table and rollers and pull the bottom film up and pass it behind the bottom idler.
- Pull the film up and place it over the top roller.
- Reposition the table by lifting the outer edge upwards and pivot in towards the roller (Figure 14).

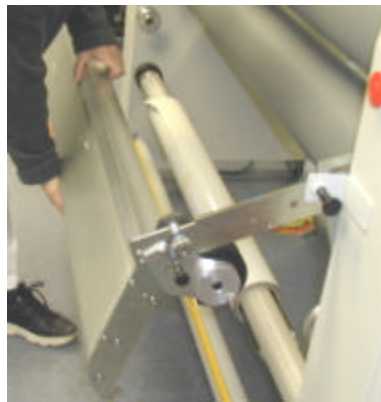

Figure 14. Table Pivoting Up

- With the table resting on the table bracket standoffs, lift the outer edge of the table and push the table in towards the roller (see Figure 15).



Figure 15. Pivoting Table Forwards

- The non-locking retaining plunger will catch automatically.
- Moving to the right hand side of the table release the locking retaining plunger so it locks in place.
- The table operation is the same front and rear.

UNWIND BRAKE / COOLING SYSTEM OPERATION

SETTING THE UNWIND BRAKE TENSION

*Refer to the Features Page for identification.

IMPORTANT: The brake tension greatly affects the smooth flow of the laminating film.

- Adjust the unwind brake so that it applies sufficient tension to the laminate.
- Turning the unwind brake in a counter-clockwise direction increases the braking tension applied on the laminate.
- Turning the unwind brake in a clockwise direction decreases the braking tension.
- The best setting for the unwind brake tension is determined by the materials you are using and is learned through experience.

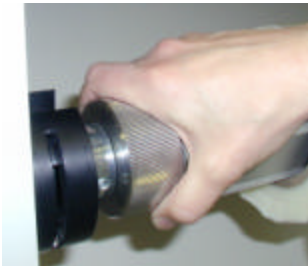

Figure 16. Unwind Brake

COOLING SYSTEM

- The Image® 6500 has a dual position cooling tube, which can be placed above or below the center chill idlers to cool heat-activated materials.
- While the majority of the time the cooling fan tube will be used in the position below the chill idlers, it can be used in the position above the chill idlers to assist with cooling down the top main roller. Pivot the airflow holes towards the top main roller.



Figure 17: Inserting Cooling Tube

To remove the cooling tube from the bottom location:

- Grasp the cooling tube with fingers or you can use your fingers in the airflow holes to lift the closed end of the cooling tube out of the bracket.
- Lift upwards at an angle, pulling the opposite open tube end out of the cabinet opening.
- Lower the open end at an angle until you can clear the upper bracket with the opposite end.
- Pull the tube up through the center of the chill idlers.

To insert the cooling tube in the top location:

- Insert the open tube end at an angle into the cabinet opening.
- Lower the closed tube end to place it in the bracket.
- Reverse the above procedures to change from the top location to the bottom location.
- The cooling tube can also be rotated to direct the airflow as needed.
- The majority of processes do not require the use of the cooling tube, but for extensive running time, it is recommended to use the cooling tube to cool off the chill idlers quicker.
- Pivot the cooling tube airflow holes towards the front idler, which receives the most heat from the heated main roller.
- Always web the film over the first idler to cool the backside of the print first, thus preventing marks on the hot front side of the print, which could affect the finished appearance.
- When using Mounting Adhesive on the back of images it is best to run the film over both idlers. Running the film under the second idler may cause the backing to separate from the release liner.

AUTO-RUN / FOOTSWITCH OPERATION

AUTO-RUN OPERATION

- The continuous-run operation allows the user to set the direction of the roller rotation and adjust the roller speed by turning either of the Speed Control knobs on the tops of the cabinets.
- This feature is useful for long runs that don't require much user control and when used in combination with the roll easel shaft and wind-up shafts can be efficient in an auto-run mode.
- Press the motor direction switch for the processing direction desired.
- Turn the speed control knob on either of the Motor Control Panels to adjust the speed of the rollers (refer to the Top Motor Control Panel page).

IMPORTANT! If the photoelectric eyes become blocked during continuous-run operation, the roller rotation will stop immediately.

IMPORTANT! Take care not to stop the motor or block the photo eyes while an image is being laminated as this can cause marks in the output.

FOOTSWITCH OPERATION

- The function of the footswitch is to permit the rotation of the rollers to be controlled in a hands-free manner.
- This feature can be used when webbing materials onto the laminator or feeding delicate images and overrides the photoelectric safety eyes.
- Pressing the footswitch runs the laminator in the direction that was pressed last (the active directional switch will be illuminated).
- The rollers will run at the speed last set which is indicated in the top display on either front or back control panels.
- The speed can be adjusted when using the footswitch by turning either speed control knob on the top of the cabinets.

WARNING! While using the footswitch, interrupting the photoelectric safety eyes does NOT stop the laminator. An audible beep will be heard, the motor directional switch will be blinking and the roller speed will run in 'slow mode' at a speed of 2ft/min (0.6 m/min.). Releasing the foot switch will stop the laminator.

- After clearing the photoelectric eye blockage the buzzer will stop.
- To resume the pre-set speed, press the blinking directional switch.

CHANGING FROM FOOTSWITCH OPERATION TO AUTO-RUN MODE WITHOUT STOPPING (to prevent stop marks on the substrate):

During footswitch operation (keep the foot switch pressed), then press Motor Direction switch desired on either Motor Control panel. The laminator will run at the pre-set speed.

Next, release the foot switch.

NOTE: Do not stop the motor or block the photo eyes while an image is being laminated as this can cause marks in the output.

THE ROTATION OF THE ROLLERS WILL STOP WHEN:

- The photoelectric eyes in the front or back of the rollers are interrupted.

CAUTION! This does NOT happen when the foot switch is used.

- An emergency stop button is pressed.
- An emergency tap switch is pressed.
- The stop button on the motor control panel is pressed.

BASIC STEPS TO FEEDING IMAGES

NOTE: For good results, the process requires that the images be fed through correctly.

- Make sure the leading edge of each image is flat all the way across or any wrinkles or creases in the image will show when laminated – perhaps even magnified.
- A straight leading edge will aid in feeding in the image.
- Feed the image into the laminator ensuring that the leading edge is parallel to the roller.

NOTE: Do not stop the motor while an image is being finished as this can cause marks in the output.

USING THE PRINT GUIDE TABLE

Your laminator may be equipped with a Front Print Guide Table to assist in feeding images into the nip. Feeding images under the print guide, directly into the nip, prevents the images from lifting up and interrupting the photo eyes.

USING THE IMAGE GUIDE ON THE FLAT TABLE

- To aid with feeding in images, the rear table is provided with an “Image Guide”.
- This device can be positioned in front of the roller and it prevents the images from interrupting the photoelectric eyes.
- The image guide can be removed when mounting boards.
- To position the Image Guide, push it completely in towards the roller aligning the outer notches with the thumbscrews in the table.
- Tighten the thumbscrews down to secure the image guide in place. You are ready to feed images.
- To assist with this, the edge of the image can be seen through the windows in the “Image Guide”, which is in front of the rollers.

USING THE ROLL EASEL ATTACHMENT

The Roll Easel Attachment is used to encapsulate images digitally reproduced with a color plotter. The rolls of images simply slip on and off the roll easel, which lifts on and off the front of the laminator.

- Mount the roll of prints on the attachment. The rolls of images should unwind with the images facing up and should be centered on the attachment so that the laminate covers the images.
- Load the Roll Easel Shaft with media into the Table/Roll Easel Brackets.

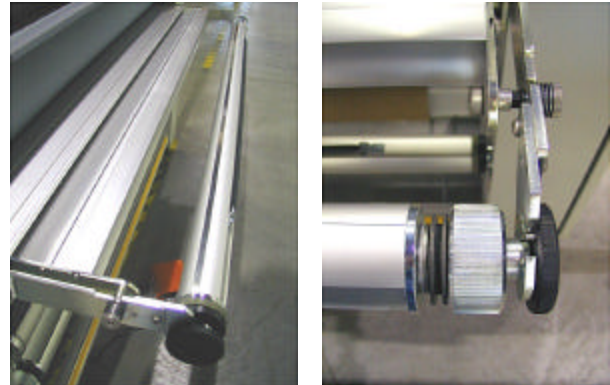

- Pivot the Roll Easel Knurled Knob end pins into the bracket notch to prevent it from pulling up and causing tracking problems.
- For the roll of images, leave some blank space at the beginning and in this space, cut out a V-shaped area to allow for an easier and cleaner start to the laminating process.
- Once the prints are running through the laminator, set the brake tension for the roll easel to exert a significant amount of tension so the prints feed through without wrinkles (refer to ‘Setting the Unwind Brake Tension’ section).
- Set the speed control to 2-3 feet or (0.6–1.0) meters per minute. Use the footswitch until the images are tracking correctly. Then press the Forward direction switch and go into auto-run mode. Don’t remove your foot from the footswitch until you have pushed the Forward direction switch. Otherwise, the laminator will stop, affecting the quality of your image’s finish.

WEBBING FILMS WITHOUT A RELEASE LINER

The following are the basic webbing procedures for webbing films without a release liner:

- Select films slightly wider than the image to allow for a border without film waste. A border of 1/8" to 1/4" (3-6mm) is adequate.
- Ensure the main roller's temperatures are set according to the recommendations of the laminates being used (see literature enclosed in your material box).

WARNING! The rollers should be down and turning while heating up to provide even heat distribution and prevent roller flat spots from developing.

- Once the laminator reaches correct operating temperature, stop the laminator and raise the top roller.
- Load and center the films on top and bottom unwind shafts with the dull adhesive side facing out and the unwind brake tension released.

NOTE: Check if the film widths of the lower and upper web are the same!

- **TOP FILM:** Pull the film down from the top unwind shaft, behind the top center idler and place it evenly over the face of the top roller.
- **BOTTOM FILM:** Pull the film up from the bottom unwind shaft, behind the front bottom idler and place it evenly over the top film draped over the face of the top roller.
- The two films will then heat and stick together.
- Set the Shim Wheels to 1/16" (2mm) to allow for the thickness of the leader-board.
- Use a leader-board to push the film(s) through the main roller nip.
- Lower the top roller and pivot the in-feed table into position.

Moving to the rear of the laminator, use the foot switch to advance the leader board.

- Feed the leader-board over the first chill idler and under the second chill idler.

NOTE: For top and bottom film combinations of 10 mil or less, feed over the first idler and under the second. For film combinations of 10 mil or over, feed over both chill idlers.

- Raise the top pull roller and advance the leader board through the pull rollers.
- Holding the leader board up against the top edge of the top pull roller lower the roller. Make sure the rear Shim Wheels are set to '0' (0mm).
- Return to the front of the laminator and set the front Shim Wheels to '-1/16' (-2mm).
- Using the footswitch advance the films, applying light unwind brake tension gradually on both unwind shafts until there are no wrinkles in the film as it goes into the nip.

You are now ready to feed images!

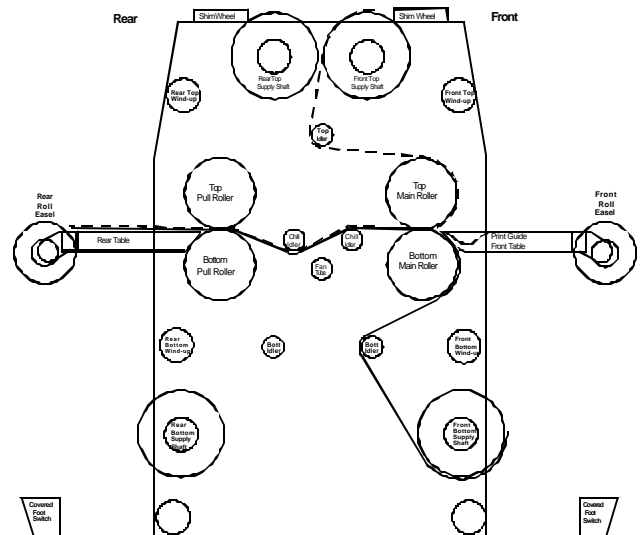

Figure 18. Webbing films w/o Release Liners

WEBBING FILMS WITH A RELEASE LINER

The following are the basic webbing procedures for webbing films with a release liner:

- Select films slightly wider than the image to allow for a border without film waste. A border of 1/8" to 1/4" (3 - 6mm) is adequate.
- Load and center the films on top and bottom unwind shafts with the dull adhesive side facing out and the unwind brake tension released.

NOTE: Check if the film widths of the lower and upper web are the same!

- **TOP FILM:** (film with a release liner) Pull the film down from the top unwind shaft, behind the top center idler and place it evenly over the face of the top roller.
- Place a spare core over the front top wind-up idler. Separate the film from the release liner. Attach the release liner to the spare core using a piece of tape.
- **BOTTOM FILM:** Pull the film up from the bottom unwind shaft, behind the front bottom idler and place it evenly over the top film draped across the face of the top roller. The two films will stick together.
- Set the Shim Wheels to 1/16" (2mm) to allow for the thickness of the leader-board.
- Use a leader-board to push the film(s) through the nip.
- Lower the top roller and pivot the in-feed table into position.
- Moving to the rear of the laminator, use the foot switch to advance the leader-board.
- Feed the leader-board over the first chill idler and under the second chill idler.

NOTE: For top and bottom film combinations of 10 mil or less, feed over the first idler and under the second. For film combinations of 10 mil or over, feed over both chill idlers.

- Raise the top pull roller and advance the leader board through the pull rollers.

- Holding the leader board up against the top edge of the top pull roller lower the roller. Make sure the rear Shim Wheels are set to '0' (0mm).
- Return to the front of the laminator and set the front Shim Wheels to -1/16 (-2mm).
- Using the footswitch advance the films, applying light unwind brake tension gradually on both unwind shafts until there are no wrinkles in the film as it goes into the nip.

YOU ARE NOW READY TO FEED IMAGES!

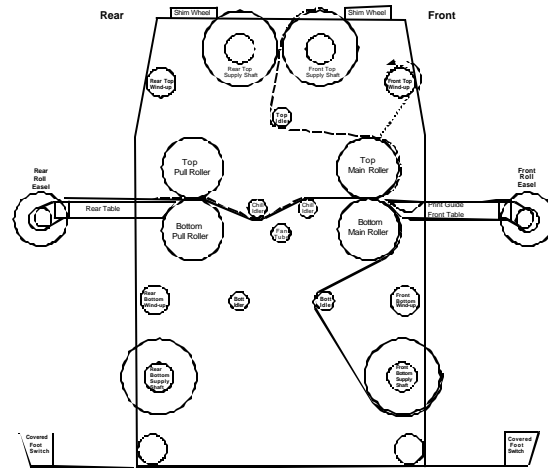

Figure 19. Webbing for North America

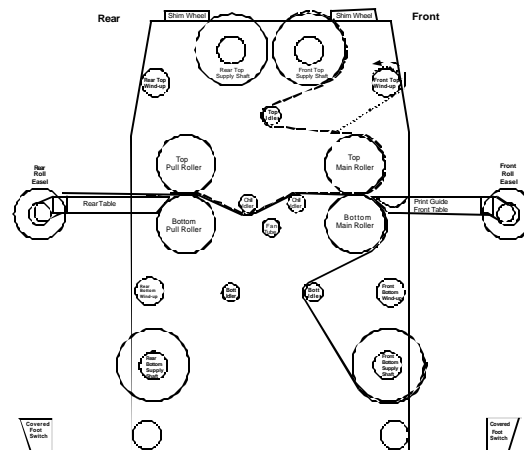

Figure 20. Webbing for Europe & Asia

DECALING (HEAT-ACTIVATED)

This process involves applying a hot film to the top and a cold backing adhesive to the bottom of the graphic. This process can be used to create self-adhesive images for mounting down onto various substrates. After performing this process, follow the Mounting Instructions in the manual to apply the decal to a substrate.

MEDIA: Ink Jet, Electrostatic and Photographic

FILMS:

- Top Unwind Shaft: Heat-activated Laminate 3 – 5 Mil
- _____ Bottom Unwind Shaft: Pressure-sensitive mounting adhesive

LAMINATOR SETTINGS

Front Control Panel

- Top Roller Temp 205-215°F (96-102°C)
- Bottom Roller Temp OFF
- Main Roller Pressure 35-40 PSI
- Cooling Fan: OFF

Back Control Panels

- Pull Rollers: Down
- Pull Roller Pressure 35-40 PSI
- Pull Clutch Tension 40-60 PSI

Motor Control Panel

- Motor Direction: Forward
- Motor Speed Setting 3-5 FPM (1-1.5 MPM)

WEBBING SETTINGS

- Web Tension Top: Medium
- Web Tension Bottom: Light
- Chill Idlers: Over 1st / Over 2nd:
- Shim Wheel Settings: -1/16 (-2mm)

NOTE: When using Mounting Adhesive on the back of images it is best to run over both idlers. Running the film under the second idler may cause the backing to separate from the release liner.

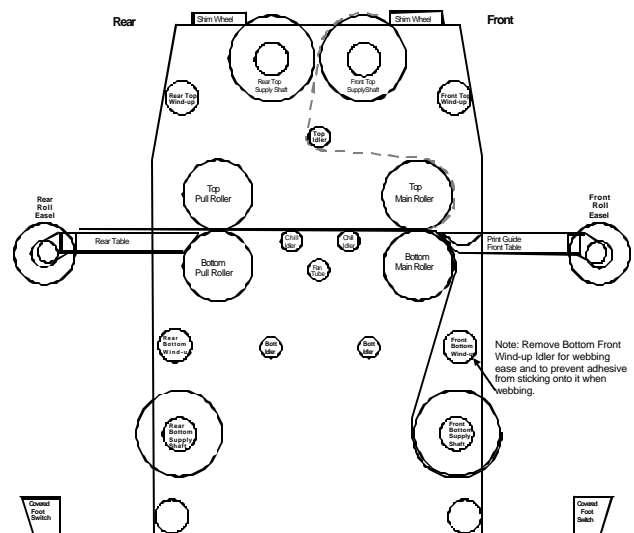

**Figure 21. Webbing for Decaling
(Heat-activated films)**

DECALING (PRESSURE-SENSITIVE)

This process involves applying a cold pressure-sensitive over-laminate to the top and a cold pressure-sensitive mounting adhesive to the bottom of a graphic. This process can be used to create self-adhesive images for mounting down onto various substrates. After performing this process, follow the Mounting Instructions in the manual to apply the decal to a substrate.

MEDIA: Ink Jet, Electrostatic, and Photographic

FILMS:

- -- Top Unwind Shaft: Pressure-sensitive over-laminate
- ___ Bottom Unwind Shaft: Pressure-sensitive mounting adhesive

LAMINATOR SETTINGS

Front Control Panel

- Top Roller Temp: OFF
- Bottom Roller Temp: OFF
- Main Roller Pressure: 35-40 PSI
- Cooling Fan: OFF

Back Control Panels

- Pull Rollers: Down
- Pull Roller Pressure: 35-40 PSI
- Pull Clutch Tension: 40-60 PSI

Motor Control Panel

- Motor Direction: Reverse
- Motor Speed Setting: 3-5 FPM (1-1.5 MPM)

WEBBING SETTINGS

- Web Tension Top: Light
- Web Tension Bottom: Light
- Chill Idlers: Over 1st / Over 2nd
- Shim Wheel Settings: -1/16 (-2mm)

NOTE: When using Mounting Adhesive on the back of images it is best to run over both idlers. Running the film under the second idler may cause the backing to separate from the release liner.

NOTE: Pressure-sensitive films, not requiring heat, can be run from the front or rear of the laminator.

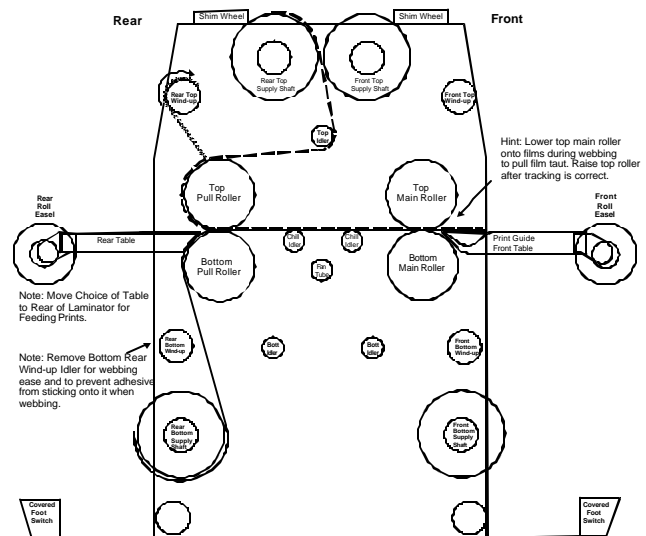

Figure 22. Webbing for Decaling (Pressure-sensitive films)

MOUNTING

This process involves mounting previously prepared decals onto a substrate. No films or adhesives are required for this process.

TO MOUNT DECALS ONTO A SUBSTRATE

- Place the mounting board on a flat surface.
- Lay your image face down on the mounting board and expose approximately 1" (25 mm) of the adhesive by peeling back the release liner along one of the edges.
- Fold the release liner back making an even crease.
- Turn the image over and carefully position the exposed adhesive edge of the image squarely onto the board.
- Once positioned correctly, press the exposed adhesive edge of the image firmly down onto the board from the center toward the edges to ensure a smooth surface. This is the edge that will be fed into the rollers first.

IMPORTANT! Ensure that the Shim Wheel settings of the rollers correspond to the board thickness.

- Push the edge of the board into the rollers and depress the foot switch until the board and image are just caught by the nip.
- Flip the un-tacked portion of the image over the top roller with one hand so that the release liner can be peeled off the image with the other hand.
- Depress the foot switch to feed the board through the rollers.

CAUTION! Because the foot switch overrides the photo eye, be sure to keep your hands clear of the rollers to prevent injury.

- At this point, continuous run can be selected by pressing the Forward Motor Direction switch.
NOTE: Take care that the rollers do not grab the liner.
- If the board is accidentally sent in too far at first, the release liner will get caught and will be impossible to pull back. In this case, stop and reverse the motor until the liner can be pulled away.
- The image must be held against the roller while the board feeds through to prevent wrinkles.
NOTE: Take care that the release liner does not trip the optical safety system.
- As the process becomes more familiar, the speed of the laminator may be increased to make the process more efficient.
- Remove the mounted image from the rear of the laminator, trim it to size and display it.



Figure 23. Mounting decals onto substrates

ENCAPSULATING

This process involves completely sealing an image between two films.

MEDIA: Ink Jet, Electrostatic, and Photographic

FILMS:

- -- Top Unwind Shaft: Heat-activated Laminate 3 – 5 Mil
- ___ Bottom Unwind Shaft: Heat-activated Laminate 3 – 5 Mil

LAMINATOR SETTINGS

Front Control Panel

- Top Roller Temp: 205-215°F (96-102°C)
- Bottom Roller Temp: 205-215°F (96-102°C)
- Main Roller Pressure: 35-40 PSI
- Cooling Fan: OFF

Back Control Panels

- Pull Rollers: Down
- Pull Roller Pressure: 35-40 PSI
- Pull Clutch Tension: 40-60 PSI

Motor Control Panel

- Motor Direction: Forward
- Motor Speed Setting: 3-5 FPM (1-1.5 MPM)

WEBBING SETTINGS

- Web Tension Top: Medium
- Web Tension Bottom: Medium
- Chill Idlers: Over 1st / Under 2nd
- Shim Wheel Settings: -1/16 (-2mm)

IMPORTANT! Follow the webbing instructions for films specific for your location.

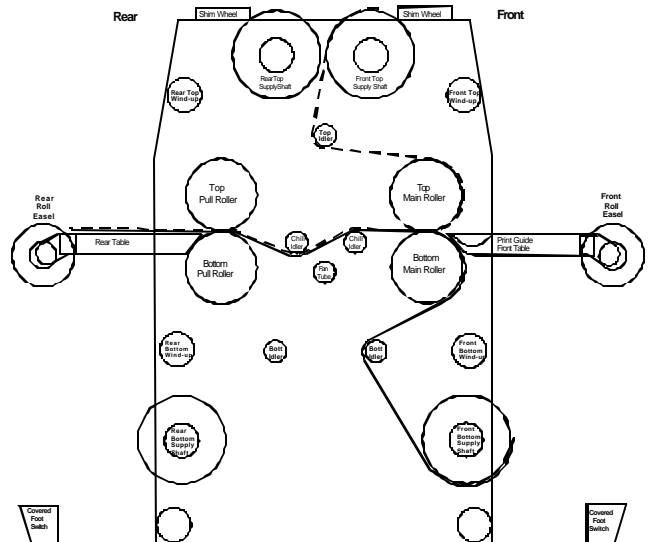

Figure 24. Webbing for Encapsulating

PRE-COATING BOARDS

This process is used to coat substrates with a self-adhesive coating onto which images can be mounted.

FILMS:

-- -- -- Top Unwind Shaft: Pressure-sensitive Mounting Adhesive
 ____ Bottom Unwind Shaft: Heat-activated Laminate 3-5 Mil (Optional)

LAMINATOR SETTINGS

Front Control Panel

Top Roller Temp: 120°F (49°C)
 Bottom Roller Temp: Optional
 Main Roller Pressure: 35-40 PSI
 Cooling Fan: OFF

Back Control Panels

Pull Rollers: Down
 Pull Roller Pressure: 35-40 PSI
 Pull Clutch Tension: 40-60 PSI

Motor Control Panel

Motor Direction: Forward
 Motor Speed Setting: 3-5 FPM (1-1.5 MPM)

WEBBING SETTINGS

Web Tension Top: Light
 Web Tension Bottom: Medium
 Chill Idlers: Over both
 Shim Wheel Settings: Substrate Dependent

IMPORTANT! Ensure that the Shim Wheel settings of the rollers correspond to the board thickness.

OPTIONAL: Adding a heat-activated laminate to the backside of the board will prevent the board from warping over an extended period of time.

WEBBING PROCEDURE

- Load the roll of pressure sensitive adhesive with the exposed adhesive facing you. Do not wrap around the top idler.
- Use a leader-board of the same thickness as the boards to be coated.
- Press the foot switch and using the leader -board, push the adhesive into the roller nip.
- Release the foot switch when the rear edge of the leader-board is almost leaving the roller nip.
- Position the board to be coated into the nip, and choose a speed setting.

NOTE: When coating boards, ensure that the next board to be coated follows the previous board without any gaps.

NOTE: Follow the last board being coated with the leader-board again to allow the final board to clear the laminating rollers and then stop the motor and raise the top roller.

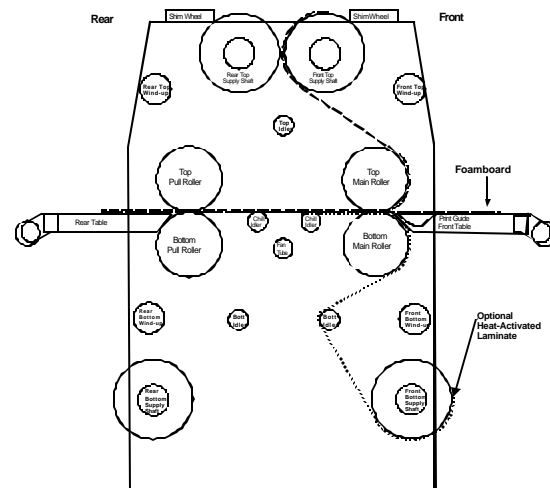

Figure 25. Pre-Coating Boards

LOW-TEMP VINYL TRANSFER

This process involves transferring an image onto a flexible vinyl. Top roller temperature and amount of main roller downward pressure is dependent on the type of toners. Use the minimum amount of pressure required for successful transfer.

MEDIA: Electrostatic

FILMS:

- -- -- Top Unwind Shaft: Media with Toners
- ___ Bottom Unwind Shaft: Banner Vinyl

LAMINATOR SETTINGS

Front Control Panel

- Top Roller Temp: 250-275°F (121-135°C)
- Bottom Roller Temp: 140-150°F (60-65°C)
- Main Roller Pressure: 80-100 PSI
- Cooling Fan: ON (Under chill idlers)

Back Control Panels

- Pull Rollers: Down
- Pull Roller Pressure: 40-60 PSI
- Pull Clutch Tension: 40-60 PSI

Motor Control Panel

- Motor Direction: Forward
- Motor Speed Setting: 1.5-5 FPM (.5-1.5 MPM)

WEBBING SETTINGS

- Web Tension Top: Medium to Heavy
- Web Tension Bottom: Light to Medium
- Chill Idlers: Over 1st / Under 2nd
- Shim Wheel Settings: -1/16 (-2mm)

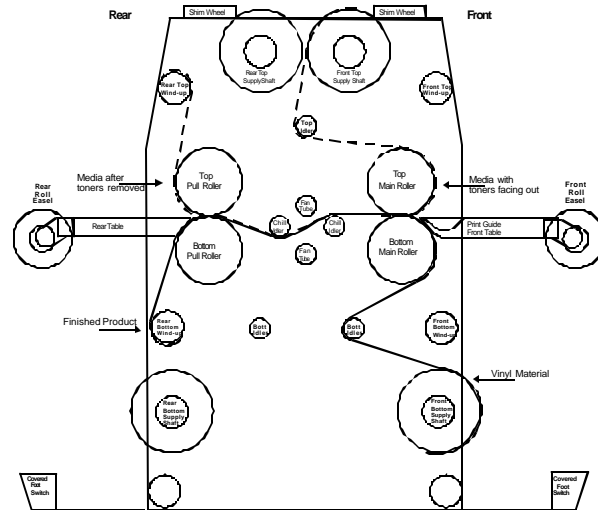

Figure 26. Webbing for Vinyl Transfer

PROCESS CONTROL SHEET

NOTE: We recommend that you make a photocopy of this page. With each successfully run application, record the process and settings and a diagram of the webbing procedure. Keep the record so the application can be repeated at a later date.

HINT: If a standard image is made available for each new process then sales materials and samples can be developed for reference.

LAMINATOR SETTINGS

Media: _____
 Process: _____
 Application Use: _____
 Top Unwind Shaft: _____
 Bottom Unwind Shaft: _____

Front Control Panel Settings

Top Roller Temp: _____
 Bottom Roller Temp: _____
 Main Roller Pressure: _____
 Cooling Fan: On / Off _____

Back Control Panel Settings

Pull Rollers: Up / Down _____
 Pull Roller Pressure: _____
 Pull Clutch Tension: _____

Motor Control Panel Settings

Motor Direction: Forward / Reverse _____
 Motor Speed Setting: _____

WEBBING SETTINGS

Chill Idlers: [Over/Under] 1st / 2nd _____
 Web Tension Top Unwind Shaft:
 Light / Med. / Heavy _____
 Web Tension Bottom Unwind Shaft:
 Light / Med. / Heavy _____
 Shim Wheel Settings: Front / Back _____
 Images: Sheet Fed / Roll Easel _____

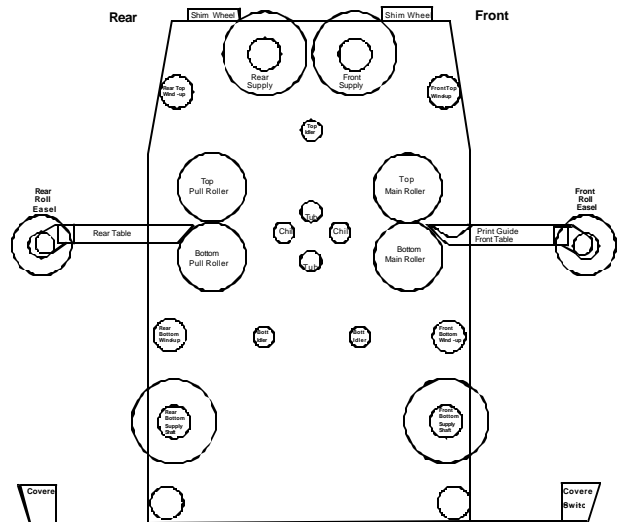

CLEANING / MAINTAINING YOUR LAMINATOR

WARNING! Turn the door interlock to the OFF Position and then disconnect the laminator from the power supply before cleaning or greasing the bearings.

CLEANING THE LAMINATOR

- The laminator may be cleaned with a lint-free cloth, lightly dampened with a mild soap and water solution. Do not use spray-on cleaners. Do not immerse any part of the laminator in water or other liquids.
- Do not use an abrasive cleaner, which can damage the painted surfaces.
- Do not allow water or liquids to enter the electrical circuits, which may cause personal injury and/or damage the equipment when power is applied.

GREASING THE BEARINGS

- You must grease the top and bottom roller bearings once each month or every 200 hours. Refer to the Grease Gun Kit included in your accessory kit for supplies and instructions.

WARNING! Failure to lube bearings will cause premature wear, which may cause costly repairs and will void your warranty.

Call Technical Service for further assistance (see rear cover).

CLEANING THE ROLLERS

IMPORTANT: Clean the laminating rollers every day to prevent adhesive build-up and to ensure quality output. Adhesive build up may eventually damage the rollers.

- When laminating, a small amount of adhesive will squeeze out between the laminate films and onto the top and bottom rollers. This residue accumulates through normal use and can be easily cleaned off the rollers.
- Use the Image roll-cleaner (included) to remove the excess adhesive from the rollers. This is best done with the rollers hot.

WARNING! Use only an Image Roll Cleaner or a cotton cloth and Isopropyl Alcohol (IPA) to clean the rollers. Do not use other solvents or cleaners. Use of other cleaners or solvents may cause roller damage and will void the warranty.

- When cleaning the upper roller, place a piece of scrap foam board under the roller to prevent the removed adhesive remnants from falling onto the lower roller.
- For adhesive that is difficult to remove, allow the rollers to cool and use isopropyl alcohol (IPA) and a clean, lint-free cloth. Never pour isopropyl alcohol (IPA) directly onto the unit.

CAUTION! Always use care when using Isopropyl Alcohol (IPA)! IPA is very flammable. The flash point of IPA is 51.8°F (11°C). The self-ignition temperature is 752°F (400°C). Wear rubber gloves and use in a well-ventilated area.

TROUBLE SHOOTING GUIDE





Problem	Solution
The laminator will not turn on.	<ul style="list-style-type: none"> • Check if the power cable is plugged into the mains wall outlet. • Check that the Stand-by switch is ON. • Unplug the laminator and check the circuit breakers inside the left cabinet. Only authorized safety or maintenance personnel should do this. • Make sure the left side cabinet door is closed and the Door interlock is in the ON position. Turning the door interlock to the OFF position automatically shuts the laminator power off.
The motor will not run.	<ul style="list-style-type: none"> • Make sure that the photo-eyes are not blocked. • Make sure that the Emergency Stop buttons were not activated. Rotate to reset. • Check that either the Forward or Reverse Motor Direction switch is pressed (switch will be illuminated). • Turn the motor speed up. • Unplug the laminator and check the fuses. Only authorized safety or maintenance personnel should do this.
The laminator is not heating up or shows erratic temperature readings.	<ul style="list-style-type: none"> • Make sure the heater switch is ON – the LED light is lit. • Make sure the rollers are together (with both shim wheel settings set at '0') and turning at a moderate speed when first heating up.
Images or Prints are rippling or jumping as they are fed into the nip.	<ul style="list-style-type: none"> • Apply tension to Images or Prints as they are fed into the nip. Hold cut sheets back by hand.
The film output is rippled or wavy (boat-waking)	<ul style="list-style-type: none"> • Check that you have webbed the laminator correctly. • Improper film tension – most encapsulating films need a minimal amount of brake tension. • Run the laminator at a higher speed for photo materials or heat-sensitive prints because exposure to heat at low speeds can cause waving.
The film is cloudy or mottled.	<ul style="list-style-type: none"> • Increase the roller temperature or decrease the motor speed. • Thicker films may require increased roller pressure due to the thicker film layer.

TECHNICAL SERVICE

For technical assistance, please contact your Technical Service representative (see rear cover).

When calling for Technical Service please have the Laminator Serial Number (listed on the Identification Plate) available. The Identification plate is located on the rear side of the laminator.

ERROR CODES

Error Messages In Speed Display	Cause	Solution
	<ul style="list-style-type: none"> One of the Emergency stop push buttons is pressed There is no power to the Main board 	<ul style="list-style-type: none"> Reset the Emergency stop pushbutton Check the Emergency Stop Buttons' wiring Check the Fuses F7 or F8
	<ul style="list-style-type: none"> Rear Photo-eye is interrupted 	<ul style="list-style-type: none"> Remove the obstruction Adjust the Photo-eye sensor
	<ul style="list-style-type: none"> Front Photo-eye is interrupted 	<ul style="list-style-type: none"> Remove the obstruction Adjust the Photo-eye sensor
	<ul style="list-style-type: none"> One of the Auxiliary Stop Switches has been pressed 	<ul style="list-style-type: none"> Check to see if something is pressing on the switch Restart the
	<ul style="list-style-type: none"> Drive motor is in overload 	<ul style="list-style-type: none"> The motor is overloaded – Restart the laminator by switching the laminator off at the main switch

Error Messages In Temperature Display	Cause	Solution
No Display Lights	<ul style="list-style-type: none"> No Power Supply 	<ul style="list-style-type: none"> Check the Fuses F1, F2 and F3
Er 3	<ul style="list-style-type: none"> The temperature does not increase after the heater has been switched on for 20 minutes 	<ul style="list-style-type: none"> Contact Technical Service

IMPORTANT! If any other error messages appear, contact Technical Service (see rear cover)

GLOSSARY OF TERMS

Decal:

An image that has been laminated on top (either heat-activated or pressure-sensitive) with an adhesive backing

Film:

A synonym for laminate. The material used in the laminating and encapsulating process

Heat-Activated Films:

Films with an adhesive that is activated when heat is applied. Once applied to an image the adhesive forms a strong bond adhering the laminate and the image together.

In-Feed:

The side of the laminator from which images are fed

Leader-Board:

A piece of foam board (about 4' x 4") used to push films into the nip. Also used for mounting or pre-coating boards to prevent adhesive from getting onto the rollers and sealing edges.

LED:

Light Emitting Diode

Mil:

Refers to the thickness of the laminate in 1/1000ths of an inch. One Mil is equal to .0254mm or 25 micron.

Mounting:

Applying an image onto some kind of foam board or substrate.

Nip:

The spot where the top and bottom rollers meet

Out-Feed:

The side of the laminator from which completed images emerge

Pre-Coating:

The process of coating a substrate with an adhesive mounting film onto which an image can be mounted.

Press:

The amount of force in distance put on anything that passes between the top and bottom rollers.

Pressure-Sensitive Films:

Films with an adhesive that is activated when pressure is applied, forming a bond between the protective laminate and the surface of the image. Used primarily for fast mounting applications and recommended for heat-sensitive thermal and photographic prints.

Release Liner:

The backing on a pressure-sensitive film or mounting adhesive. After peeling the release liner off, the adhesive layer becomes exposed.

Sled:

A board that has a non-stick surface that is used when laminating one side of an image only.

Substrate:

The material to which an image is mounted or affixed

SPARE PARTS LIST

PART DESCRIPTION	PART #	PART DESCRIPTION	PART #
Accessory Pack	1151	Heater Anti-sag Spring	275210
Air Compressor	225020	Heater Element	148045
Air Clutch	104666	Heater, Bracket	511653
Air Cylinder, Main Kit	55044	Key, Locking Cabinets	053610
Air Cylinder, Pull Kit	55046	Motor	107551
Air Filter Kit	5514	Photo-electric Eye	160106
Air Gauge Kit	55069	Relay, Omron	166040
Air Regulator Kit	50607	Relay, Solid State	166064
Chain, 35-Connecting Link	10136	Roll, Main	691698
Chain, 40-Connecting Link	101038	Roll,.Pull	691699
Chain, Clutch Drive	101021	Roll Easel Shaft Kit	5529
Chain, Main Drive	101020	Switch, Motor – Green	175064
Chain, Lovejoy Tensioner Kit	5515	Switch, Motor – Red	175063
Chain, Mini-Tensioner Kit	5516	Solenoid, (Air Valve)	250610
Chill Idler Kit	5517	Table, Image Guide (Front)	5521
Circuit Breaker, 25Amp	129720	Table, Print Guide (Rear)	5522
Circuit Breaker, 50Amp	129725	Take-Up Shaft Kit	5518
Clutch, Take-up Adj. Kit	6106	Take-up Shaft Rack Kit.	55076
Cluch, Take-up Drive Kit	6107	Take-up Spare Core	8207042
Door Disconnect	143025	Thermostat	178150
Fan Tube	615463	Unwind Shaft Kit	5527
Fan Tube, End Cap	134004	Unwind Shaft, Locking Cords	569367
Fan Tube Opening Cover Kit	5523		
Fan Tube, O-Ring	169003		

TECHNICAL SPECIFICATIONS

Mechanical	
Dimensions (H x W x D)	56" x 85" x 57" (1423 mm x 2159 mm x 1448 mm)
Net Weight	1,710 lbs. (775 kg)
Shipping Weight	2,260 lbs. (1025 kg)
Roller Construction	Four high release silicone-covered rollers
Process	
Max. Working Width	61" maximum (1550 mm)
Max. Roller Speed	15 ft/min. (4.5 m/min.)
Core Inner Diameter	3" (76 mm)
Maximum Board Thickness	1" (25.4 mm)
Nip Settings	0, 1/16, 1/8, 3/16, 1/4, 3/8, 1/2, 3/4, 1 and -1/16" (0, 2, 3, 5, 6, 10, 13, 19, 25 and -2 mm)
Max. Main Roller Temperature	275°F (135°C)
Electrical	
Electrical Requirements	
Single phase version	200-240V, AC 50/60Hz, 48A, 2/G
Three phase version	230/400V, AC 50/60Hz, 22A, 3N/PE
Maximum Power consumption	11,000 watts
NOTE: Airborne Noise	Less than 70DB(A)
Order Codes	
SEAL [®] Image [®] 6500, Single phase	60424
SEAL [®] Image [®] 6500, Single phase, International	60426
SEAL [®] Image [®] 6500, Three phase	60425

Each SEAL[®] Image[®] laminator has a Serial Number Label. This label indicates the model type, the electrical requirements, and the laminator serial number (important for reference if any servicing is required).

The Serial Number Label is located on the right side cabinet when facing the rear.

LIMITED WARRANTY

SEAL® Graphics warrants to the original consumer purchaser that each new SEAL® Image® Laminator, which proves defective in materials or workmanship within the applicable warranty period, will be repaired or, at our option, replaced without charge.

Effective November 1st, 2002 the applicable warranty period for New Equipment shall be one year (parts), six months (labor and rollers) from date of purchase.

This warranty extends to and is enforceable by only the original consumer purchaser, and only for the period (during the applicable term), which the product remains in the possession of the original consumer purchaser. "Original consumer purchaser" means the person who first purchased the product covered by this warranty other than for purpose of resale. This warranty does not apply if it is found that at any time the equipment has not been used for its intended purpose.

Effective November 1st, 2002 the applicable warranty period for Refurbished Equipment shall be ninety days (parts and labor, excluding rollers). Rollers are not covered under warranty. The applicable warranty period for Demo Equipment shall vary, not exceeding the maximum warranty period stated herein. All Demo Equipment comes with a specific warranty, which will be stated at the time of purchase. If warranty period is not detailed in writing, there is no remaining warranty.

Please ask your dealer, distributor, or sales representative for details.

NOTE: Used and Not Refurbished Equipment is sold on an "AS IS" basis with No Warranty.

For more information regarding this warranty, please contact your distributor.

WARNING! Any unauthorized changes or modifications to this unit without our prior written approval will void the user's warranty and will transfer health and safety obligations to the user.

WARNING! Changes or modifications to this unit not expressly approved by the party responsible for compliance could void the user's authority to operate the equipment

NOTE: This equipment has been tested and found to comply with the limits for a class A digital device, pursuant to part 15 of the FCC rules. These limits are designed to provide reasonable protection against harmful interference when the equipment is operated in a commercial environment. This equipment generates uses and can radiate radio frequency energy and, if not installed and used in accordance with Owner's Manual, may cause harmful interference to radio communications. Operation of this equipment in a residential area is likely to cause harmful interference in which case the user will be required to correct the interference at their own expense.

©Copyright SEAL® Graphics 2002

All rights are reserved. No part of the document may be photocopied, reproduced, or translated to another language without the prior written consent of SEAL Graphics.

The information contained in this document is subject to change without notice and should not be construed as a commitment by SEAL Graphics.

SEAL Graphics assumes no responsibility for any errors that may appear in this document. Nor does it make expressed or implied warranty of any kind with regard to this material, including, but not limited to, the implied warranties of merchantability and fitness for a particular purpose.

SEAL Graphics shall not be liable for incidental or consequential damages in connection with, or arising out of the furnishing, performance, or use of this document and the program material, which it describes.

Trademarks Credits

SEAL® is a registered trademark of SEAL Graphics.

Image® is a registered trademark of SEAL Graphics.

AquaSEAL® is a registered trademark of SEAL Graphics.

ProSEAL® is a registered trademark of SEAL Graphics.

SEAL_a Brands Technical Service

(For technical assistance & service)

Tel: 1-800-486-6502

Fax: 1-800-966-4554

SEAL_a Brands Technical Service – Europe and Asia Pacific

(For technical assistance & service)

For UK: Tel: +44 1268 722 400

Fax: +44 1268 729 442 or +44 870 125 5798

For NL: Tel: +31 572 345 500

Fax: +31 572 345 501

SEAL_a Brands Customer Service

(For information and placing orders)

Tel: 1-800-257-7325

Fax: 1-800-966-4554

SEAL_a Brands Customer Service – Europe and Asia Pacific

(For information and placing orders)

Tel: +31 572 345 500

Fax: +31 572 345 501

Note: SEAL Graphics recommends that your main power be installed by a licensed electrician in accordance with electrical codes in your area. Specifications subject to change without notice.

**Seal Graphics
Americas Corporation**
7091 Troy Hill Drive
Elkridge, MD 21075
Tel: 410-379-5400
Fax: 410-579-8960

Seal Graphics Canada
1601 Matheson Blvd. E.
Unit #4
Mississauga, Ontario
Canada, L4W 1H9
Tel: 905-212-9232
Fax: 905-212-9313

Seal Graphics U.K. Ltd
Unit 1, 1 Watkins Close
Burnt Mills Industrial Estate
Basildon, Essex SS13 1BJ
United Kingdom
Tel: +44 1268 722 400
Fax: +44 1268 729 442

Seal Graphics Europe BV
Kanaaldijk O.Z.3
P.O. Box 29,
8100 AA Raalte
The Netherlands
Tel: +31 572 345 500
Fax: +31 572 345 501

**Seal Graphics Pacific
Limited**
Unit A, 13th Floor, Block 1
Leader Industrial Centre
Tsuen Wan,
New Territories, Hong Kong
Tel: +852 2407 3738
Fax: +852 2408 0973



www.sealbrands.com

© 2002 SEAL Graphics
SEAL_a and Image_a are registered trademarks of SEAL Graphics
Part #OM6500-E Rev. B
(11/02)