

Owner's Operation Manual

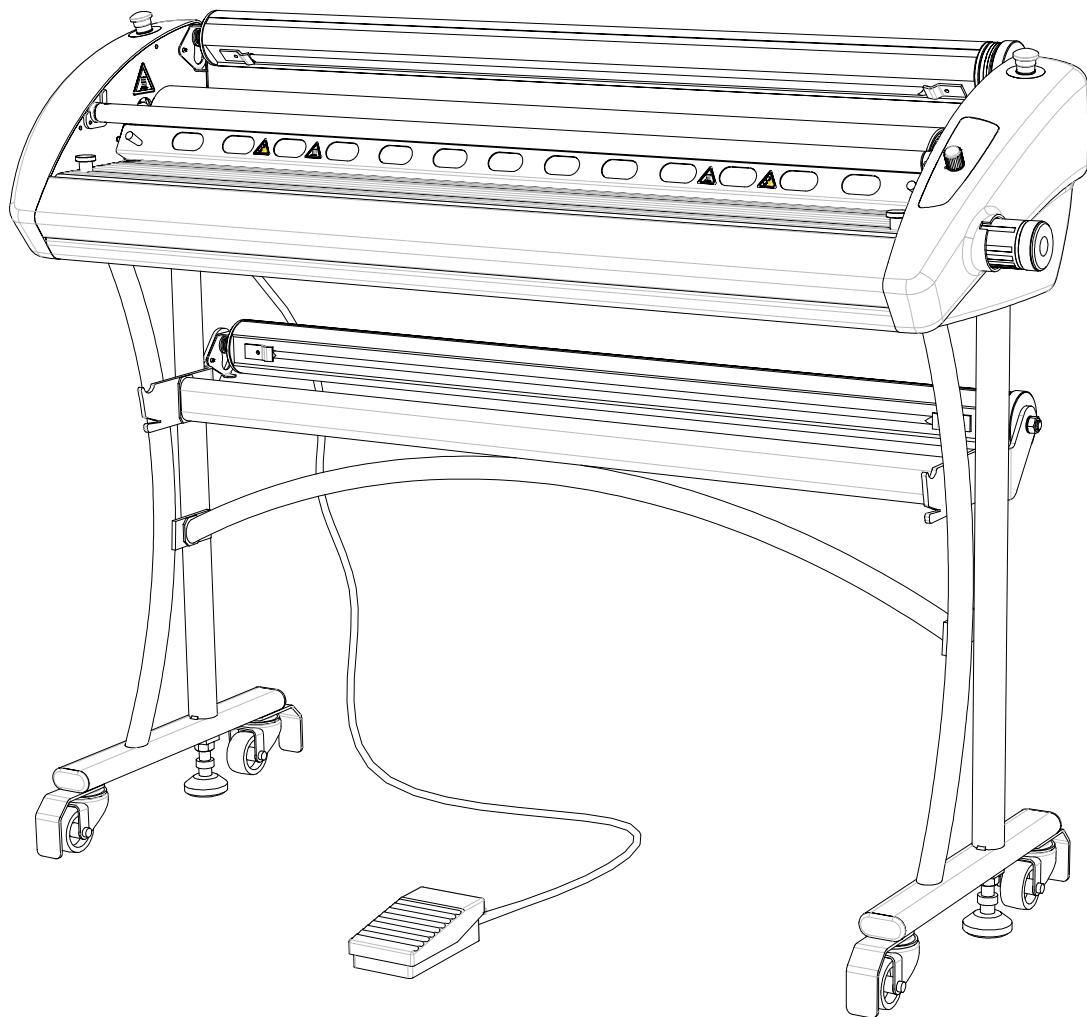



Seal Brands ... the finishing touch.

TABLE OF CONTENTS

Introduction	3
Technical Specifications	4
Electrical Specifications	5
Installation	6
Unpacking and Set-up	7
Safety and Important Safeguards	10
Laminator Features	11
Control Panel	12
Operating Your Laminator	13
Set-up and Operation	14
Image Guide	16
Webbing Films Without a Release Liner	17
Webbing Films With a Release Liner (North America)	18
Webbing Films With a Release Liner (Europe & Asia)	19
Decaling	20
Mounting	21
Encapsulating	22
Pre-Coating Boards	23
Using A ProSEAL™ Mounting Board And ProSEAL Pouch Board	24
Encapsulating Using a ProSEAL Flexible Pouch With a ProSEAL Sled	25
Cleaning	26
Trouble Shooting Guide	27
Glossary of Terms	28
Limited Warranty	29
Contact Information	Rear Cover

INTRODUCTION

Thank you for purchasing a SEAL® 44/62 Ultra Laminator. We have designed the 44/62 Ultra to give you years of reliable service. As you become familiar with the 44/62 Ultra Laminator, you will appreciate the high quality of its production and the excellence in its engineering design.

By following the guidelines for proper care and use of the 44/62 Ultra, you can depend on many years of trouble-free profitability from your investment.

The purpose of this manual is to outline the materials and process when using SEAL Brands supplies with your laminator to create signs, displays, and flexible graphics with professional results. The manual includes instructions of various laminating procedures, which are meant to give you comprehensive information needed for the efficient use of your laminator.

Please read and fully understand the entire manual before proceeding to use your laminator.

STATEMENT OF INTENDED USE

Your 44/62 Ultra Laminator meets the CE Machinery Safety Directive (89/392/EEC, including 91/368/EEC, 93/44/EEC and 93/68/EEC) and is cETL listed (UL 1950/EN60950).

The 44/62 Ultra laminator has been designed to be used with SEAL Brands materials. When used with these products, you are able to mount, mount and laminate, and encapsulate prints in one step. Your laminator has been tested with SEAL Brands supplies and we recommend using these products for professional results.

WARNING! This laminator is designed for mounting and laminating. Any use other than the intended may cause damage to the laminator or physical harm to the user.

LIABILITY STATEMENT

The details given in this manual are based on the most recent information available to us. They may be subject to change in the future. We retain the right to make changes to the construction or the design of our products without accepting any responsibility for modifying earlier versions previously delivered.

CAUTION! Please pay attention to all passages marked this way. This information is vital to preventing user injury and/or damage to the unit. Failure to follow this information could void the user's warranties and transfer all safety obligations to the user.

TECHNICAL SPECIFICATIONS

Mechanical

Dimensions (H x W x D)	44 Ultra	43.7" x 58.3" x 22" (1110 x 1480 x 560 mm)
	62 Ultra	43.7" x 76.3" x 22" (1110 x 1940 x 560 mm)
Shipping dimensions (H x W x D)	44 Ultra	28.4" x 63" x 24.8" (720 x 1600 x 630 mm)
	62 Ultra	28.4" x 81" x 24.8" (720 x 2060 x 630 mm)
Net Weight	44 Ultra	222 lbs. (101 kg)
	62 Ultra	311 lbs. (140 kg)
Shipping Weight	44 Ultra	297 lbs. (135 kg)
	62 Ultra	416 lbs. (189 kg)
Roller Construction		Two silicone-covered steel rollers

Process

Maximum Working Width (processes up to 50°C)	44 Ultra	44" (1118 mm)
	62 Ultra	62" (1574 mm)
	44 Ultra	42" (1067 mm)
		62 Ultra
Roller Line Pressure	44 Ultra	5.54 lbf/in (0.97 N/mm)
	62 Ultra	4.43 lbf/in (0.78 N/mm)
Maximum Speed		4.92 ft/min. (1.5 mtr/min.)
Maximum Roll Diameter	top unwind (supply)	6.3" (160 mm)
	bottom unwind (supply)	8" (200 mm)
	wind-up (release liner)	5" (125 mm)
Maximum Board Thickness		0.393" = 3/8" (10 mm)
Core size		3" (76.2 mm)
Nip Settings		0, 1/16", 1/8", 3/16", 1/4", 5/16", 3/8" (0, 2, 3, 5, 6, 8 and 10 mm)
Temperature Settings		Off (ambient temperature), 125°F, 195°F, 250°F (50°C, 90°C, 120°C)

Electrical Requirements

(see also next page)

SEAL 44 Ultra	(EU-version)	1N/PE 230V +/-10%, 50/60Hz, 9A
	(NA-version)	1N/PE 110V +/-10%, 50/60Hz, 16A
SEAL 62 Ultra	(EU-version)	1N/PE 230V +/-10%, 50/60Hz, 13A
	(NA-version)	1N/PE 230V +/-10%, 50/60Hz, 13A

ELECTRICAL SPECIFICATIONS

The electrical specifications of the laminators are:

North American Versions:

For the North American 110V version,
the following is applicable:

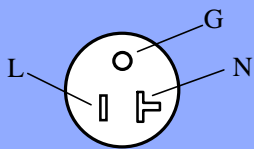

NEMA 5-20R
Using 20 Amp Breaker
Note: T-slot is not applicable for
Canada

EU Versions:

For the EU versions, Mainland Europe,
the following is applicable:

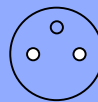

France
Belgium

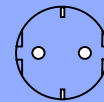

Germany, The Netherlands
Portugal, Spain

Use the provided Schuko plug (10A).

For the North American 230V version,
the following is applicable:

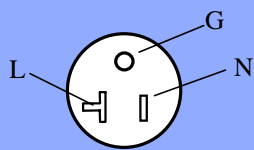

NEMA 6-20R
Using 20 Amp Breaker
Note: T-slot is not applicable for
Canada

For the EU versions, in the UK,
the following is applicable:

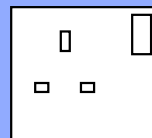

BS 1363 – 13A
wall receptacle:
Use the provided
BS 1363 plug

INSTALLATION

WORKSPACE REQUIREMENTS

- This unit should be situated away from heat sources such as heat registers or stoves/ovens.
- The laminator's location or position should not interfere with its proper ventilation.
- There should be enough space around the laminator to feed-in, exit, and trim mounted and/or laminated images.
- Keep the area around your laminator clear with adequate space around it so you can feed, receive and trim mounted and / or laminated images.
- The work area should be level, flat, and well lit.

Accessories Included:

- Wrench 17-24 mm
- 10 each Socket head screws
- 10 each Star Washers
- 2 each Spare Fuses (250V)
- Allen key (5 mm)
- Snitty Safety Knife
- Image Roll Cleaner
- Spare Core for Wind-up Idler
- Leader-board

ENVIRONMENT CONDITIONS

The following environmental conditions are ideal for the best operation of the laminator.

AMBIENT TEMPERATURE

The best temperature for the 44/62 Ultra is between 16°C and 35°C (50°F and 95°F).

Do not expose the laminator to direct sunlight as output quality may be affected.

RELATIVE HUMIDITY

For best results, the ambient relative humidity for the 44/62 Ultra should be between 70% and 90%.

WATER AND MOISTURE

If the laminator is installed in a damp room or near water, the electrical power supply must be in accordance with the standards prevailing in the country concerned.

SURROUNDINGS

Install the laminator in surroundings that are as clean and dust free as possible in order to obtain the highest quality end product.

The background dust level must not exceed that found in a typical office/computer room environment.

The materials that are used on this laminator can have an electrostatic charge and will attract dust, adversely affecting the output.

POWER SUPPLY

Connect the laminator in accordance with the details given on the identification plate attached to the rear of the laminator. Refer also to the Technical Specifications page for more information.

UNPACKING AND SET-UP

Remove the cardboard box and the plastic bag as described on the outside of the box.

Remove and open the boxes behind the laminator, which contains the stand parts.

SETTING UP THE LAMINATOR IN 4 STEPS

STEP 1

- Mount the left-hand stand leg onto the underside of the laminator, as shown in Figure 1.

(Note: The left-hand section is recognizable by a spring utility on the bracket.)

- Use two star washers and two socket-head screws.
- Do not tighten these screws completely.

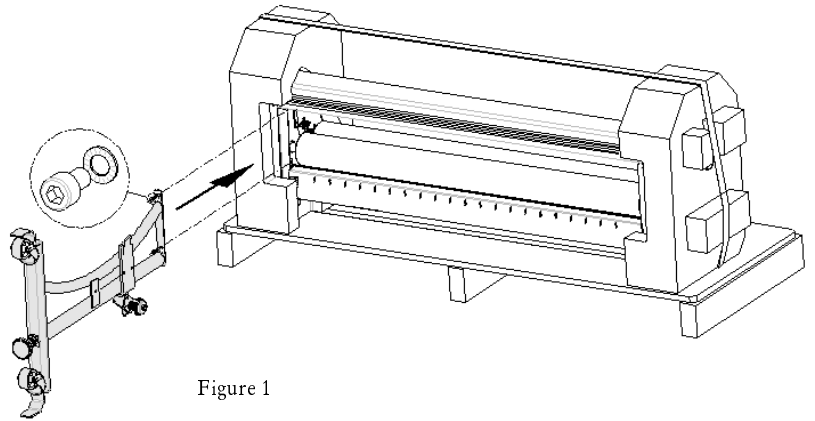

Figure 1

STEP 2

- Mount the right-hand stand leg onto underside of the laminator, as shown in Figure 2.
- Use two star washers and two socket-head screws.
- Do not tighten these screws completely.

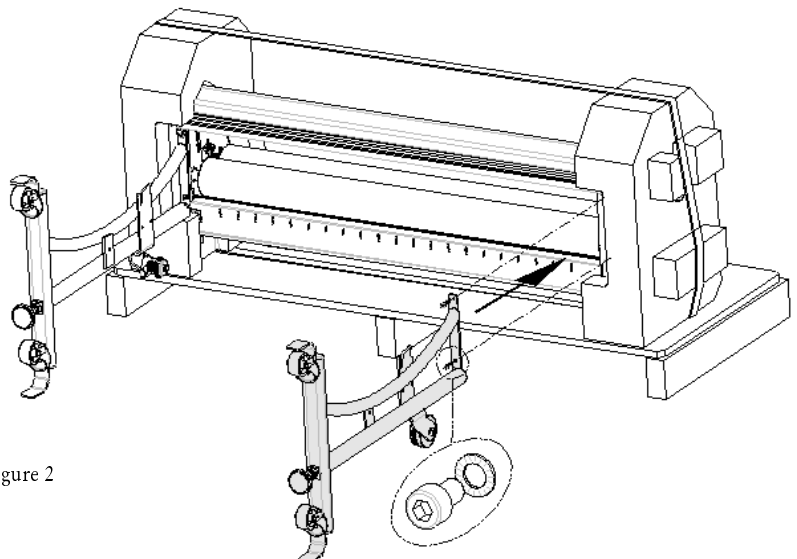

Figure 2

UNPACKING AND SET-UP

STEP 3

- Now mount the middle support section between the left-hand and right-hand stand legs, as shown in Figure 3.
- Use six star washers and six socket-head screws.
- Tighten these six screws.
- Finally, tighten all screws, which were used in Steps 1 and 2.

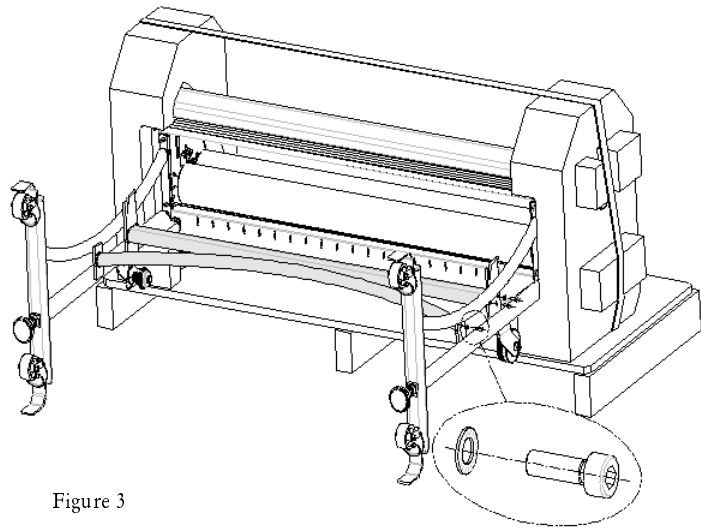

Figure 3

STEP 4

- Carefully lift the laminator (at least two people must do this!) from the pallet and position it onto its castors as shown in Figure 4.
- Make sure that the stand legs do not slide away during lifting.
- Cut the strap and remove the protective covers.

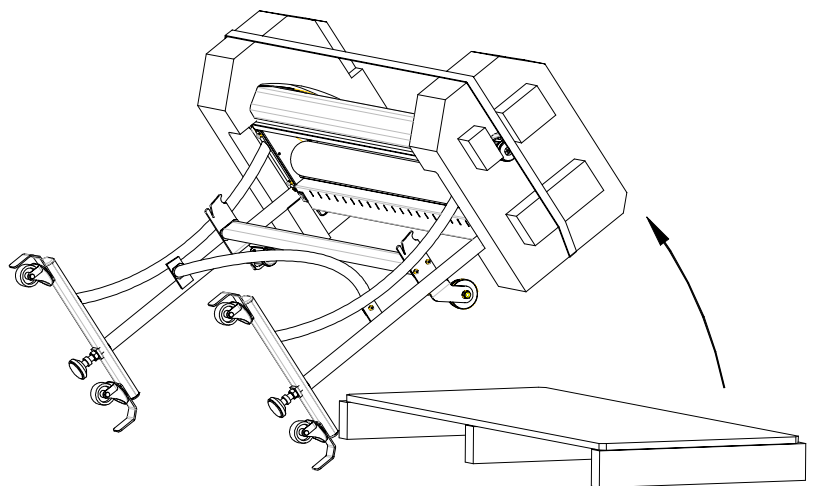

Figure 4

UNPACKING AND SET-UP

LAMINATOR PLACEMENT

- Your 44/62 Ultra must be setup in the location where it will be used. The stand must be placed on a flat level surface.
- Remove the tie-wraps by using a small flat-edged screwdriver to press the clip to release the tie and remove the blocks that hold the top roller.
- Inspect the laminator for any physical damage.

ADJUSTABLE FEET

- To secure the stand on the floor, turn the adjustable foot down by hand, until it's pressed against the floor.
- Manually lock the adjustable foot with the nut. (Figure 5)

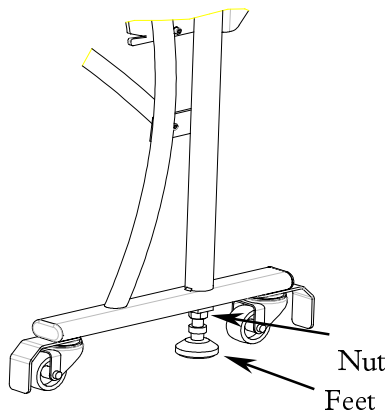

Figure 5

CONNECTING YOUR LAMINATOR

- Plug the power cable into the grounded outlet with the appropriate service. (Refer to the Electrical Specifications Page)
- The 44/62 Ultra must be installed next to an outlet!
Do not use extension cords!
- The plug and the outlet must be easily accessible.
- Please ensure that you plug your laminator into a grounded, three-prong outlet.
- Please ensure that the total load of the other items using the same circuit breaker do not exceed its breaking value.
- The laminator should only be connected to a power supply outlet of the voltage and amperage marked on the rear panel. (See Identification Plate on laminator rear panel.)
- The laminator has a grounded plug (three prongs). To reduce the risk of electrical shock, this plug is intended to fit only a grounded outlet of the proper amperage, and only in one way.

WARNING! Any unauthorized changes or modifications to this unit without our prior written approval will void the user's warranty and will transfer health and safety obligations to the user.

IMPORTANT SAFEGUARDS

SAFETY SYMBOLS USED ON THE LAMINATOR



Rotating Parts: Risk of Injury

Failure to use caution near rotating rollers could result in physical injury. Be careful that items such as loose clothing, long hair and jewelry do not become entangled in rotating parts.



Hot Surface: Risk of Injury on Contact

The laminator contains a heated top roller which may reach temperatures of 135°C (275°F). There is a danger of severe burns if the heated top roller is touched during use. Even after switching off the laminator, the roller remains hot for a long time.

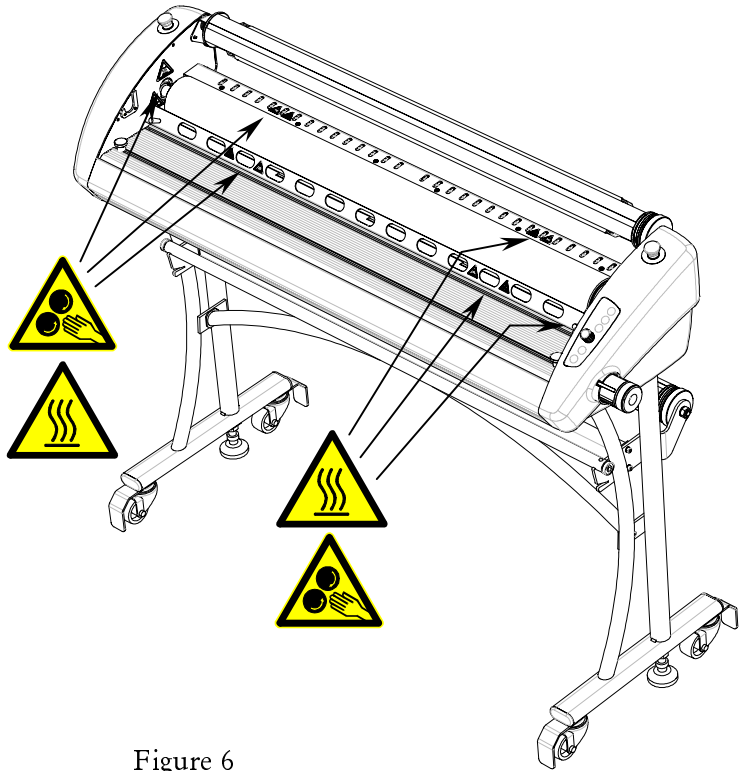

Figure 6

EMERGENCY STOP-BUTTONS

There are two Emergency-Stop Buttons located on the top of the left and right plastic covers of the laminator.

The Emergency-Stop Buttons stop the rotation of the rollers and should only be used in case of an emergency. Once pressed, these buttons lock, and they must be rotated to be reset before the laminator can be used again.

LAMINATOR FEATURES

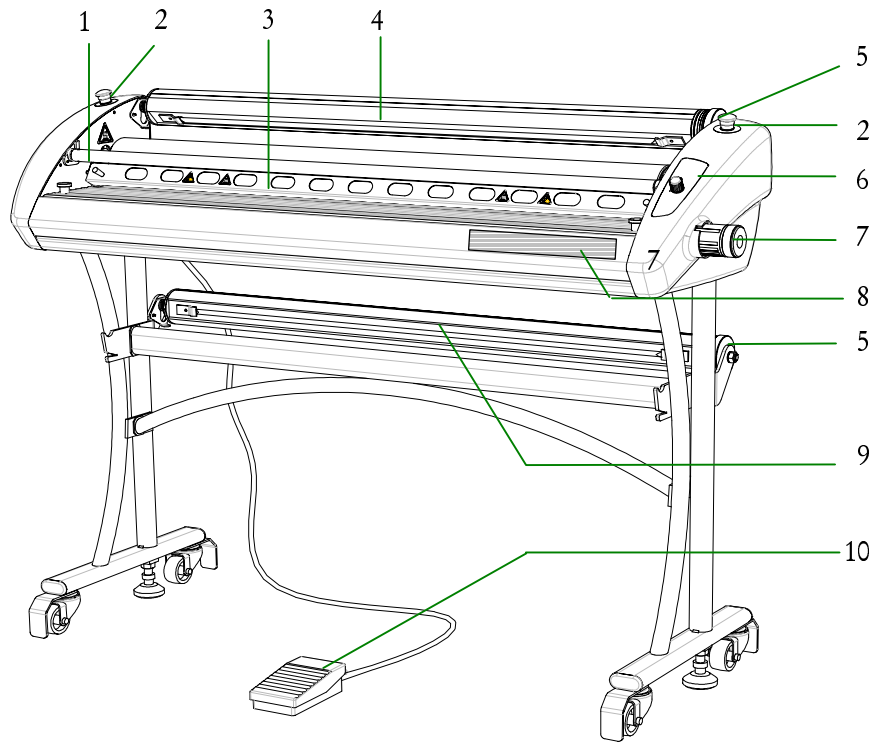

Figure 7

Description of Parts

1	Wind-up idler	Idler (removable) to support the wind-up core for the release-liner.
2	Emergency stop button	Stops the rotation of the rollers.
3	Image guide	To help feed in images. It is removable when mounting.
4	Upper unwind shaft	The shaft is suitable for rolls wound onto a 3-inch ID core.
5	Unwind brake	A simple braking system with a knurled collar provides the means of setting the brake tension.
6	Control panel	Controls roller rotation, temperature and standby mode.
7	Nip knob	To adjust the gap between the rollers.
8	Process control label	Shows how to preset the laminator.
9	Lower unwind shaft	The shaft is suitable for rolls wound onto a 3-inch ID core.
10	Foot switch	To engage slow-mode that overrides the photo-electric safety eyes.

CONTROL PANEL

LED INDICATOR DESIGN

The LED indicators are designed to indicate the on/off status of power, heat, and roller direction. Please see below for the definitions of the LED status indicators.

PUSH BUTTON DESIGN

The Push Buttons control whether power and heat is on or off and the direction the rolls turn. Please see below for detailed instructions.

NOTE: Push the Power Button (at least one-sec.) and the forward (or reverse) button on the control panel, to run the laminator

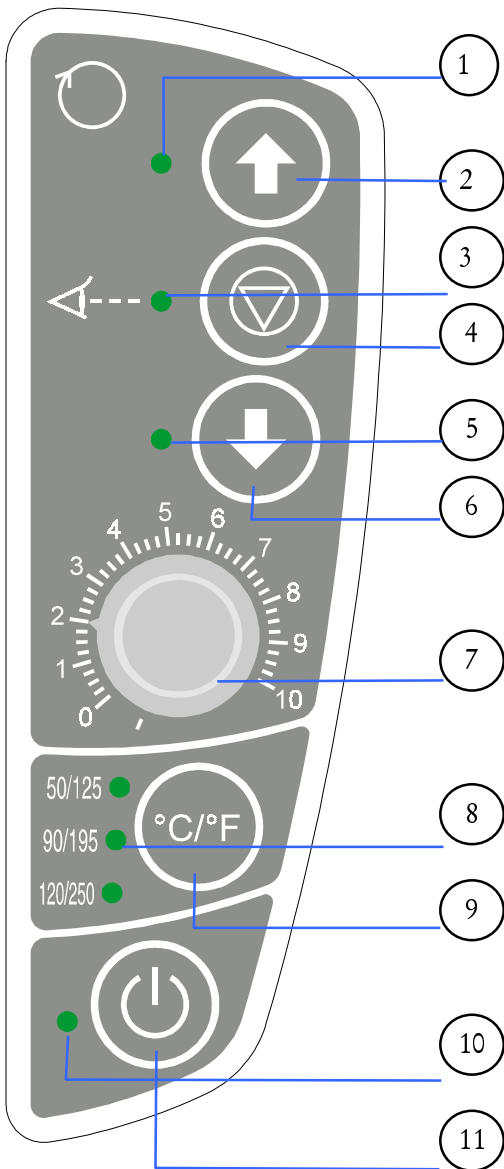

- | | | |
|----|------------------------------|--|
| 1 | LED - Forward Run | Lit when the rollers run in forwards direction. |
| 2 | Button - Forward Run | Push button to run rollers in forwards direction. |
| 3 | LED Optical Safety System | Lit when light beam is not interrupted. |
| 4 | Button - Stop | Push button to stop. |
| 5 | LED - Reverse Run | Lit when the rollers run in reverse direction. |
| 6 | Button - Reverse Run | Push button to run rollers in reverse direction. |
| 7 | Speed Adjustment Knob | Each whole number represents an increase or decrease in speed of 60/min. (15cm/min.). |
| 8 | LED's - Temperature Settings | Lit to correspond to temperature setting. |
| 9 | Button - Temperature Setting | Toggle push button to preset the temperature. (press 2 seconds to switch the heating system off) |
| 10 | LED - Power | Lit when laminator is switched on. |
| 11 | Button - Power | Toggle push-button to turn laminator ON/OFF (press 2 seconds). |

Figure 8

OPERATING YOUR LAMINATOR

MOTOR CONTROL

The speed of the rollers is continuously adjustable between 0 and 1.5 m/min. (0 and 4.8 ft/min.)

Pressing the $\hat{\uparrow}$ button runs the rollers in the forward direction, pressing the $\hat{\downarrow}$ button reverses the direction of the rollers. The stop button stops the roller movement.

SLOW-MODE OPERATION

The laminator has a slow-mode, which can be activated by pressing the foot switch.

- To maintain slow-mode, keep the foot switch pressed.
- This feature can be used when loading materials onto the laminator and overrides the photo-electric safety eyes.

Once the laminator is running in slow-mode, interrupting the photo-electric safety eyes does NOT stop the laminator. An audible beep will be heard and the roller speed will be 0.6 m/min. (2 ft/min). Releasing the foot switch will stop the laminator.

CHANGING FROM SLOW-MODE TO NORMAL RUNNING MODE WITHOUT STOPPING (to prevent stop marks on the substrate):

- During slow-mode (keep the foot switch pressed), press the $\hat{\uparrow}$ (forward) button on the control panel. The laminator will run at the pre-set speed.
- Next, release the foot switch.
- Finally, release the $\hat{\uparrow}$ (forward) button.

CHANGING FROM NORMAL MODE TO SLOW-MODE WITHOUT STOPPING:

- Press the foot switch.

NOTE: Releasing the foot switch will stop the laminator.

REVERSING THE ROLLER ROTATION

- To reverse the rotation of the rollers, press the $\hat{\downarrow}$ (reverse) button.
- As long as the button is pressed, the laminator will run in the reverse direction, at a speed of 0.6m/min. (2 ft/min) only.
- Releasing the button will stop the laminator.

Use caution so that loose clothing, long hair, jewelry and fingers are not pinched between the pull rollers at the rear side of the laminator.

THE ROTATION OF THE ROLLERS WILL STOP WHEN:

- The photo-electric eyes in front of the main rollers are interrupted.

NOTE: This does NOT happen when the foot switch is used (slow-mode).

- An emergency stop button is pressed.
- The foot switch is pressed for a short moment.
- Excessive unwind tensions are set (the motor will be shut off electronically. Press the stop button on the control panel to reset).
- The stop button on the control panel is pressed.

SET-UP AND OPERATION

The following steps outline the basic procedures that have to be used for loading films; setting the nips, webbing the laminator and setting the brake tension for the films you will be using. To load and unload the unwind shafts, it is necessary to access the laminator from the rear side.

Select the film(s) that you will use on the top (and bottom) of the images. It is advisable to use films slightly wider than the print width. This way the print can be trimmed with a border, to reduce waste, yet leave enough for a border.

ALWAYS WORK IN THE CENTER OF THE LAMINATOR.

LOADING THE FILM ONTO THE UNWIND SHAFT

- Remove the desired unwind shaft (2), top or bottom by pushing the interlock bracket (1) in the upper position and sliding the unwind shaft to the right against the spring pressure. (Figure 9)
- Release the interlock bracket when the shaft is completely to the right.
- Lift the unwind shaft out of the laminator.
- Slide the shaft into a film roll. Ensure that the rubber blocking cords are on the top and bottom of the shaft for easy loading.

Take care that the ends of the shaft do not become damaged during the loading and unloading.

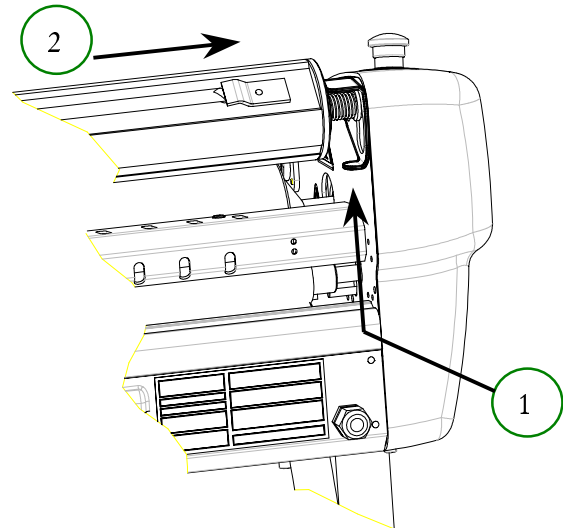

Figure 9

LOADING THE UNWIND SHAFT INTO THE LAMINATOR

- Place the unwind shaft (2), top or bottom including the material, into the laminator by inserting it onto the left-hand unwind shaft holder.
- Push the interlock bracket (1) upward with your finger before sliding the unwind shaft further. (Figure 9)
- Press against the spring pressure, until you can place the other end of the shaft onto the right-hand holder and onto the left-hand side holder.
- Center the film roll in the laminator.
- Rotate the unwind shaft until it locks into the unwind brake.

SET-UP AND OPERATION

SETTING THE UNWIND BRAKE TENSION

(Refer to the Features Page for identification.)

- Tighten the unwind brake so that it applies sufficient tension to the laminate.
- Turning the unwind brake in a clockwise direction increases the braking tension applied on the laminate.
- Turning the unwind brake in a counter-clockwise direction decreases the braking tension.
- The best setting for the unwind brake tension is determined by the materials you are using and is learned through experience.

TEMPERATURE SETTINGS

- Select the film(s) that you will use on the top (and bottom) of the images.
- Check which temperature setting is recommended for your SEAL® Brands material (see literature enclosed in your material box).
- Refer to the Control Panel Diagram for information on setting the temperature.

ROLLER NIP SETTINGS

Whenever you mount onto a board, etc., it is important to adjust the rollers to create a gap nearly equal to the thickness of the board being used. This is done so that anything passing between the rollers will receive the right amount of pressure and prevent damage to the roller's silicone surface (and possibly the board).

HOW TO SET THE NIP:

- First, determine the thickness of the board that you will use for mounting.
- Grasp the Nip-knob with your right hand and push it in approximately ¼" (6mm) to the left.
- Once the Nip-knob has disengaged from the stop, it may be rotated forward or backward (clockwise or counter-clockwise, as viewed from the right hand side of the unit).
- Turn until the desired measurement corresponds with the indicator window at the base of the knob.
- Releasing the Nip-knob so that it moves back to the right and clicks into place will set the rollers for use.
- The measurements on the Nip-knob correspond to the board thickness.
- There is also a fully closed stop 0" (0 mm) for film only applications.

NOTE: For non-standard substrate thickness, select the next lowest nip setting, i.e. 7mm board – select ¼" (6mm) nip.

IMAGE GUIDE

- To aid with feeding in images, the laminator is provided with an “Image Guide”.
- This device can be positioned in front of the top roller and it prevents the images from interrupting the photo-electric eyes.
- When changing the roller nip, the Image Guide moves together with the top roller.
- To position the Image Guide, place it on the brackets, as shown in Figure 10.



Figure 10

- Align the slots with the screw head and push it completely in towards the top roller.

NOTE: For good results, the process requires that the images be fed through correctly.

- The leading edge of each image must be flat all the way across or any wrinkles or creases in the image will show when encapsulated - perhaps even magnified.
- To aid with feeding in, the leading edge should also be straight.
- Feed the image into the laminator ensuring that the leading edge is parallel to the roller.
- To assist with this, the edge of the image can be seen through the windows in the “Image Guide”, which is in front of the rollers.

NOTE: Do not stop the motor while an image is being finished as this can cause marks in the output.

- When not in use, the Image Guide and the wind-up idler can be stored in the stand. (Figure 11)

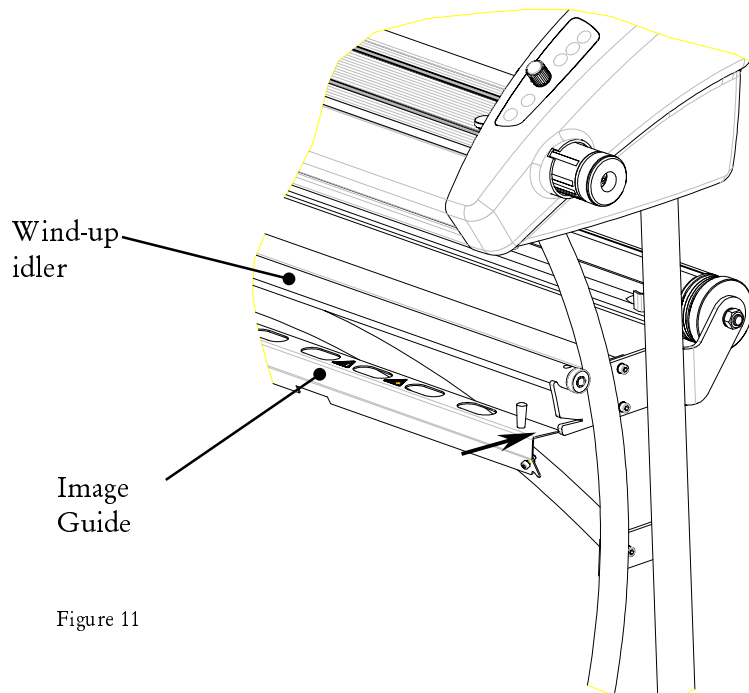

Figure 11

WEBBING FILMS WITHOUT A RELEASE LINER

The following are the basic webbing procedures for webbing films without a release liner:

- Select films slightly wider than the image to allow for a border without film waste. A border of 1/8" to 1/4" is adequate.
- Ensure the main roller's temperatures are set according to the recommendations of the laminates being used. Refer to the process guide on the front of the laminator.

WARNING! *The rollers should be down and turning while heating up to provide even heat distribution and prevent roller flat spots from developing.*

- Once the laminator reaches correct operating temperature, stop the laminator and raise the top roller.
- Load and center the films on top and bottom unwind shafts with the dull adhesive side facing out and the unwind brake tension released.

NOTE: *Check if the film widths of the lower and upper web are the same!*

- Remove the image guide, the in-feed table and the wind-up idler
- **TOP FILM:** Pull the film down from the top unwind shaft and place it evenly over the face of the top roller.
- **BOTTOM FILM:** Pull the film up from the bottom unwind shaft and place it evenly over the face of the top roller
- The two films will then heat and stick together.

- Set the Nip-knob to 1/16" (2mm) to allow for the thickness of the leader-board.
- **FILMS INTO NIP:** Use the provided leader-board to push the film(s) through the nip.
- Lower the top roller and place the in-feed table into position.

NOTE: *Keep the film under tension (turning the top unwind shaft, not the film roll manually) to prevent the photo-electric eyes being tripped.*

- Using the foot switch, advance the leader-board between the pull rollers until the end comes out through the pull-rollers.
- Release the foot switch and set the Nip knob to '0' (0mm).
- Moving to the rear of the laminator, with the film and leader-board hanging out of the laminator, cut off the leader-board.
- Return to the front of the laminator and run the laminator, applying light unwind brake tension gradually on both unwind shafts until there are no wrinkles in the film as it goes into the nip.

NOTE: *Best results will be obtained when the film unwind tension is zero or very light. Wrinkles, visible on the roller face do not show on the output.*

- Refit the image guide on the in-feed table.

YOU ARE NOW READY TO FEED IMAGES!

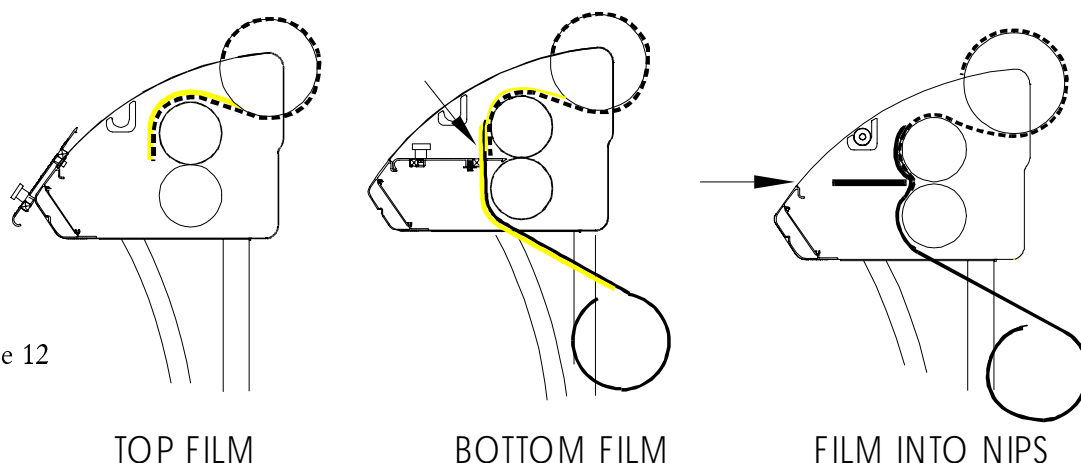

Figure 12

WEBBING FILMS WITH A RELEASE LINER (NORTH AMERICA)

The following are the basic webbing procedures for webbing films with a release liner:

- Select films slightly wider than the image to allow for a border without film waste. A border of 1/8" to 1/4" is adequate.
- Load and center the films on top and bottom unwind shafts with the dull adhesive side facing out and the unwind brake tension released.

NOTE: Check if the film widths of the lower and upper web are the same!

- Remove the image guide, the in-feed table and the wind-up idler
- **TOP FILM:** (film with a release liner) Pull the film down from the top unwind shaft and place it evenly over the face of the top roller.
- Replace the wind-up idler into the brackets.
- Place the spare core between the wind-up idler and the top main roller.
- Separate the film from the release liner.
- Attach the release liner to the spare core using a piece of tape.
- **BOTTOM FILM:** Pull the film up from the bottom unwind shaft and place it evenly over the top film across the face of the top roller
- Set the Nip-knob to 1/16" (2mm) to allow for the thickness of the leader-board.

- **FILMS INTO NIP:** Use the provided leader-board to push the film(s) through the nip.
- Lower the top roller and place the in-feed table into position.

NOTE: Keep the film under tension (turning the top unwind shaft, not the film roll manually) to prevent the photo-electric eyes being tripped.

- Using the foot switch, advance the leader-board between the pull rollers until the end comes out through the pull-rollers.
- Release the foot switch and set the Nip knob to '0' (0mm).
- Moving to the rear of the laminator, with the film and leader-board hanging out of the laminator, cut off the leader-board.
- Return to the front of the laminator and run the laminator, applying light unwind brake tension gradually on both unwind shafts until there are no wrinkles in the film as it goes into the nip.

NOTE: Best results will be obtained when the film unwind tension is zero or very light. Wrinkles, visible on the roller face do not show on the output.

- Refit the image guide on the in-feed table.

YOU ARE NOW READY TO FEED IMAGES!

Figure 13

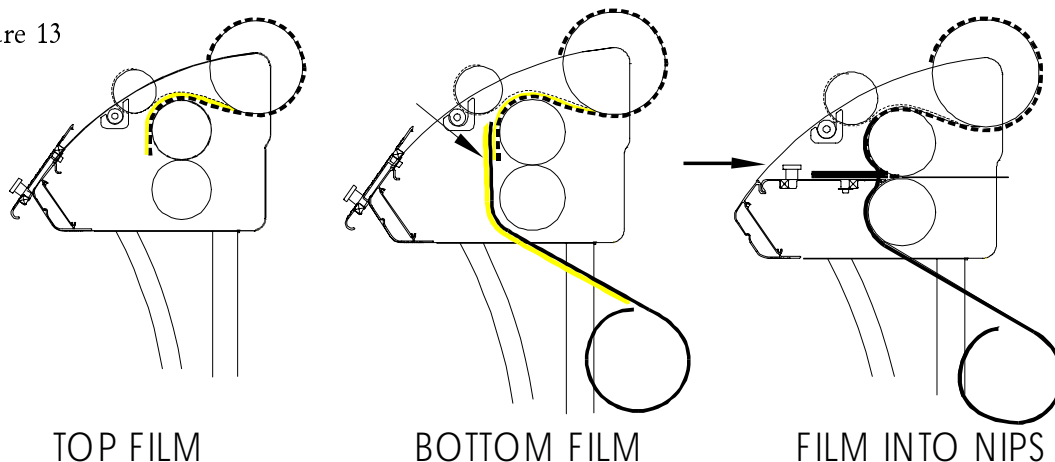

WEBBING FILMS WITH A RELEASE LINER (EUROPE & ASIA)

The following are the basic webbing procedures for webbing films with a release liner:

- Select films slightly wider than the image to allow for a border without film waste. A border of 1/8" to 1/4" is adequate.
- Load and center the films on top and bottom unwind shafts with the dull adhesive side facing out and the unwind brake tension released.

NOTE: Check if the film widths of the lower and upper web are the same!

- Remove the image guide, the in-feed table and the wind-up idler
- TOP FILM: (film with a release liner) Pull the film down from the top unwind shaft and place it evenly over the face of the top roller.
- Replace the wind-up idler into the brackets.
- Place the spare core between the wind-up idler and the top main roller.
- Separate the film from the release liner.
- Attach the release liner to the spare core using a piece of tape.
- BOTTOM FILM: . Pull the film up from the bottom unwind shaft and place it evenly over the top film across the face of the top roller
- Set the Nip-knob to 1/16" (2mm) to allow for the thickness of the leader-board.

- FILMS INTO NIP: Use the provided leader-board to push the film(s) through the nip.
- Lower the top roller and place the in-feed table into position.

NOTE: Keep the film under tension (turning the top unwind shaft, not the film roll manually) to prevent the photo-electric eyes being tripped.

- Using the foot switch, advance the leader-board between the pull rollers until the end comes out through the pull-rollers.
- Release the foot switch and set the Nip knob to '0' (0mm).
- Moving to the rear of the laminator, with the film and leader-board hanging out of the laminator, cut off the leader-board.
- Return to the front of the laminator and run the laminator, applying light unwind brake tension gradually on both unwind shafts until there are no wrinkles in the film as it goes into the nip.

NOTE: Best results will be obtained when the film unwind tension is zero or very light. Wrinkles, visible on the roller face do not show on the output.

- Refit the image guide on the in-feed table.

YOU ARE NOW READY TO FEED IMAGES!

Figure 14

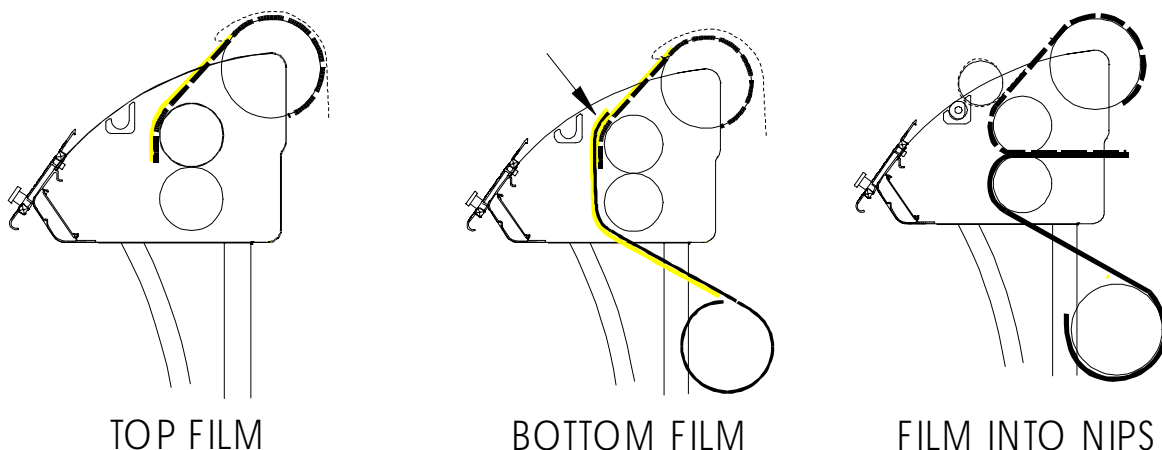

DECALING

This process involves sandwiching an image between a pressure-sensitive or heat-activated laminate on the face of the image and a pressure-sensitive adhesive on the rear. This process can be used to create self-adhesive images for mounting down onto various substrates.

After performing this process, follow the Mounting Instructions in the manual to apply the decal to a substrate.

- Select films slightly wider than the image to allow for a border without film waste. A border of 1/8" to ¼" is adequate.
- Refer to the process guide on the front of the laminator for settings and recommended film combinations.
- Follow the webbing instructions for the type of films being used which are specific to your location.

MOUNTING

This process involves mounting previously prepared decals onto a substrate. No films or adhesives are required for this process.

To perform this process, it is necessary to remove the Image Guide. You can store the Image Guide in the laminator stand (Figure 9).

TO MOUNT DECALS ONTO A SUBSTRATE

- Place the mounting board on a flat surface.
- Lay your image face down on the mounting board and expose approximately 1" (25 mm) of the adhesive by peeling back the release paper along one of the edges.
- Fold the release paper back making an even crease.
- Turn the image over and carefully position the exposed adhesive edge of the image squarely onto the board.
- Once positioned correctly, press the image firmly down onto the exposed adhesive from the center toward the edges to ensure smooth surface. This is the edge that will be fed into the rollers first.
- Ensure that the nip setting of the rollers corresponds to the board thickness.
- Push the edge of the board into the rollers and depress the foot switch until the board and image are just caught by the nip.
- Flip the un-tacked portion of the image over the top roller with one hand so that the release paper can be peeled off the image with the other hand.
- Depress the foot switch to feed the board through the rollers.
- At this point, continuous run can be selected by pressing one of the speed settings.

NOTE: Take care that the rollers do not grab the liner.

- When the end of the board is near the nip, you may want to slow the laminator down. To do this, just press the foot switch to go into slow-mode. Releasing the foot switch will stop the laminator.
- Remove the mounted image from the rear of the laminator and trim it if necessary.
- If the board is accidentally sent in too far at first, the release liner will get caught and will be impossible to pull back. In this case, stop and reverse the motor until the liner can be pulled away.
- The image must be held against the roller while the board feeds through to prevent wrinkles. As the process becomes more familiar, the speed of the laminator may be increased to make the process more efficient.

NOTE: Take care that the release liner does not trip the optical safety system.

ENCAPSULATING

This process involves completely sealing an image between two films.

- Follow the webbing instructions for films specific for your location.
- Select films slightly wider than the image to allow for a border without film waste. A border of 1/8" to 1/4" is adequate.
- Ensure the main roller's temperatures are set according to the recommendations of the films being used. Refer to the process guide on the front of the laminator.

WARNING! *The rollers should be down and turning while heating up to provide even heat distribution and prevent roller flat spots from developing.*

- Once the laminator reaches correct operating temperature, stop the laminator and raise the top roller.
- Load and center the films on top and bottom unwind shafts with the dull adhesive side facing out and the unwind brake tension released.

NOTE: *Check if the film widths of the lower and upper web are the same!*

- Remove the image guide, the in-feed table and the wind-up idler
- **TOP FILM:** Pull the film down from the top unwind shaft and place it evenly over the face of the top roller.
- **BOTTOM FILM:** Pull the film up from the bottom unwind shaft and place it evenly over the top film over the face of the top roller.

- The two films will then heat and stick together.
- Set the Nip-knob to 1/16" (2mm) to allow for the thickness of the leader-board.
- **FILMS INTO NIP:** Use the provided leader-board to push the film(s) through the nip.
- Lower the top roller and place the in-feed table into position.

NOTE: *Keep the film under tension (turning the top unwind shaft, not the film roll manually) to prevent the photo-electric eyes being tripped.*

- Using the foot switch, advance the leader-board between the pull rollers until the end comes out through the pull-rollers.
- Release the foot switch and set the Nip knob to '0' (0mm).
- Moving to the rear of the laminator, with the film and leader-board hanging out of the laminator, cut off the leader-board.
- Return to the front of the laminator and run the laminator, applying light unwind brake tension gradually on both unwind shafts until there are no wrinkles in the film as it goes into the nip.

NOTE: *Best results will be obtained when the film unwind tension is zero or very light. Wrinkles, visible on the roller face do not show on the output.*

- Refit the image guide on the in-feed table.

YOU ARE NOW READY TO FEED IMAGES!

PRE-COATING BOARDS

This process is used to coat substrates with a self-adhesive coating onto which images can be mounted.

Preparation:

- Load the roll of pressure sensitive adhesive onto the top unwind shaft of the laminator with the exposed adhesive facing you.
- Use a leader-board of the same thickness as the boards to be coated.
- Pull the adhesive down from the top unwind shaft and place evenly across the face of both main rollers.
- Remove the in-feed table and the Image Guide for a moment to do this.
- Measure the thickness of the board(s) to be coated, and select the correct nip setting.
- Press the foot switch and using the leader-board, push the adhesive into the roller nip.
- Release the foot switch when the rear edge of the leader-board is almost leaving the roller nip.
- Position the board to be coated into the nip, and choose a speed setting.

NOTE: When coating boards, ensure that the next board to be coated follows the previous board without any gaps.

NOTE: Follow the last board being coated with the leader-board again to allow the final board to clear the laminating rollers and then stop the motor and raise the top roller.

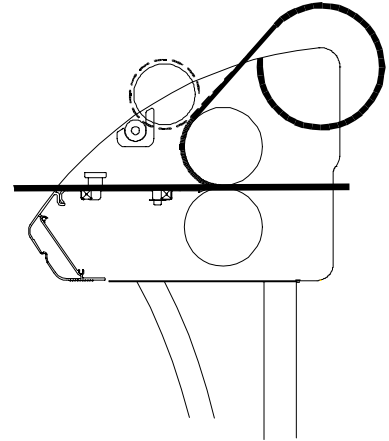

Figure 15

Webbing for Europe & Asia

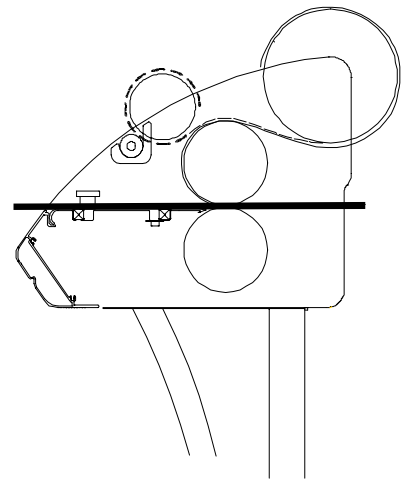

Figure 16

Webbing for U.S., Canada & Latin America

USING A ProSEAL™ MOUNTING BOARD & POUCH BOARDS

USING A ProSEAL MOUNTING BOARD

- Refer to the instruction sheet packed with each box of ProSEAL Mounting Boards for specific instructions on mounting with a ProSEAL Board.
- Also, refer to the instruction sheet for information on Compatible Media, Process Conditions and Technical Information.
- Place the image to be mounted on the adhesive-coated side of the mounting board (dull side of the board).
- Cover your print with the “cover sheet” as marked; (included with each box of ProSEAL Mounting Boards); please be sure that the board is completely covered by this sheet.
- Set the Nip Knob to the correct setting that matches the Mounting Board thickness.
- Insert the board into the inlet opening. Ensure the board will enter centered and straight. A gentle push may be required to start the board into the laminator.
- Hold the edges of the board until it is engaged in the unit and the laminator begins pulling it on its own.
- The board will feed through the laminator and automatically exit at the rear of the unit.

CAUTION! *The board will be hot! Allow it to lie flat while cooling.*

USING A ProSEAL POUCH BOARD

- Refer to the instruction sheet packed with each box of ProSEAL Pouch Boards for specific instructions on mounting/laminating with a ProSEAL Board.
- Also, refer to the instruction sheet for information on Compatible Media, Process Conditions and Technical Information.
- Carefully examine the board to determine which edge is sealed. There is a 1/8” (3mm) tape edge on the sealed end.
- Starting at one of the corners, opposite the sealed edge, gently lift and peel back the film. Care should be taken not to break the sealed hinge.
- Center the image to be laminated on the board and lay the film back over it.
- Set the Nip Knob to the correct setting that matches the Pouch Board thickness.
- Slowly insert the Pouch Board into the inlet opening. Ensure that the Pouch Board will enter centered and straight. A gentle push may be required to start the board into the laminator.
- Hold the edges of the Pouch board until it is engaged and the laminator begins pulling it on its own.
- The Pouch Board will feed through the laminator and automatically exit at the rear of the unit.

CAUTION! *The board will be hot! Allow it to lie flat while cooling.*

- If there is any dirt or adhesive on the surface of the board, it can be removed by dampening a lint free cloth with ISO Propyl Alcohol (IPA) and wiping the surface.

CAUTION! *Always use care when using Isopropyl Alcohol (IPA)! IPA is very flammable. The flash point of IPA is 11°C (51.8°F). The self-ignition temperature is 400°C (752°F).*

ENCAPSULATING USING A ProSEAL™ FLEXIBLE POUCH WITH A ProSEAL™ SLED

1. Refer to the instruction sheet packed with each box of ProSEAL Flexible Pouches for specific instructions on encapsulating.
2. Also, refer to the instruction sheet for information on Compatible Media, Process Conditions and Technical Information.
3. The ProSEAL Flexible Pouch consists of two pieces of film that are hinged at one end, along a short side. Separate the two pieces starting at the end opposite the hinge. Take care not to break the hinged seal.
4. Insert the article to be laminated in the pouch so there is at least a 1/8" (3.5mm) border around each of the sides. This ensures that moisture never reaches the image.
5. Place the pouch with the image on the sled included with the Flexible Pouches or ProSEAL Sled. (The ProSEAL Sled is a sled to assist in the handling of large Flexible Pouches. It is made of materials that will not damage or cause excessive wear to your 44/62 Ultra Laminator.)
6. Smooth out any wrinkles with the side of the hand or a soft flexible squeegee.
7. Tape the leading edge of the pouch to the sled using masking tape.
8. Adjust the Nip Knob to the 3/16" (5mm) setting for the ProSEAL Sled.
9. Be sure that the heat is on. (max. temperature)
10. Slowly insert the sled with the Flexible Pouch on top into the inlet opening.
11. Ensure that the sled is centered and straight. A gentle push may be required to start the sled into the laminator.
12. Hold the edge of the sled until it is engaged and the laminator begins pulling it on its own.
13. The sled will feed through the laminator and automatically exit at the rear of the laminator.

CAUTION! The sled will be hot! Allow it to lie flat and cool before removing the tape.
14. If there is any dirt or adhesive on the surface of the Flexible Pouch, it can be removed by dampening a lint free cloth with ISO Propyl Alcohol (IPA) and wiping the surface.

CAUTION! Always use care when using Isopropyl Alcohol (IPA)! IPA is very flammable. The flash point of IPA is 11°C (51.8°F). The self-ignition temperature is 400°C (752°F).

CLEANING

CLEANING THE LAMINATOR

Disconnect the laminator from the power supply before cleaning.

- The laminator may be cleaned with a lint-free cloth, lightly dampen with a mild soap and water solution. Do not use spray-on cleaners. Do not immerse any part of the laminator in water or other liquids.
- Do not use an abrasive cleaner, which can damage the painted surfaces.
- Do not allow water or liquids to enter the electrical circuits, which may cause personal injury and/or damage the equipment when power is applied.

CLEANING THE ROLLER

- Use the Image roll-cleaner (included) to remove the excess adhesive from the rollers. This is best done with the rollers hot.
- When cleaning the upper roller, place a piece of scrap foam board under the roller to prevent the removed adhesive remnants from falling onto the lower roller.
- For adhesive that is difficult to remove, allow the rollers to cool and use isopropyl alcohol (IPA) and a clean, lint-free cloth. Never pour isopropyl alcohol (IPA) directly onto the unit.

CAUTION! *Always use care when using Isopropyl Alcohol (IPA)! IPA is very flammable. The flash point of IPA is 11°C (51.8°F). The self-ignition temperature is 400°C (752°F).*

TROUBLE SHOOTING GUIDE

Problem	Cause	Solution
The power LED does not come on, when the laminator is switched on.	There is no power.	<ul style="list-style-type: none"> • Check if the power cable is plugged into the mains wall outlet. • Check the fuse located on the rear side.
LED - Power is flashing	The voltage from the supplier is too low.	<ul style="list-style-type: none"> • Laminator voltage 115V: The incoming voltage must be between 90-130V AC. • Laminator voltage 230V: the incoming voltage must be between 200-250V AC.
LED - Forward is flashing	Drive-motor is in overload.	<ul style="list-style-type: none"> • The laminator is in overload - restart the laminator
LED - Reverse is flashing	Drive-motor is in overload.	<ul style="list-style-type: none"> • The laminator is in overload - restart the laminator

TECHNICAL SERVICE

For technical assistance, please contact your SEAL Technical Service representative (see rear cover).

When calling for Technical Service please have the Laminator Serial Number (listed on the Identification Plate) available.

The Identification plate is located on the rear side of the laminator.

GLOSSARY OF TERMS

Decal:

An image that has been laminated on top (either heat-activated or pressure-sensitive) with an adhesive backing.

Heat-Activated Films:

Films with an adhesive that is activated when heat is applied. Once applied to an image the adhesive forms a strong bond adhering the laminate and the image together.

In-Feed:

The side of the laminator from which images are fed.

Leader-Board:

A piece of foam board (about 4' x 4") used to push films into the nip. Also used for mounting or pre-coating boards to prevent adhesive from getting onto the rollers and sealing edges.

LED:

Light Emitting Diode

Mil:

Refers to the thickness of the laminate in 1/1000ths of an inch.

Mounting:

Applying an image onto some kind of foam board or substrate.

Nip:

The spot where the top and bottom rollers meet.

Out-Feed:

The side of the laminator from which completed images emerge.

Pre-Coating:

The process of coating a substrate with an adhesive mounting film onto which an image can be mounted.

Press:

The amount of force in distance put on anything that passes between the top and bottom rollers.

Pressure-Sensitive Laminates:

Films with an adhesive that is activated when pressure is applied, forming a bond between the protective laminate and the surface of the image. Used primarily for fast mounting applications and recommended for heat-sensitive thermal and photographic prints.

Release Liner:

The backing on a pressure-sensitive film or mounting adhesive. After peeling the release liner off, the adhesive layer becomes exposed.

Substrate:

The material to which an image is mounted or affixed.

LIMITED WARRANTY

SEAL Graphics (“SEAL”) warrants to the original consumer purchaser that each new SEAL® Brands Laminator, which proves defective in materials or workmanship within the applicable warranty period, will be repaired or, at our option, replaced without charge. The applicable warranty shall be one year from date of purchase with the exception of silicone roll coverings that will be six months from date of purchase. "Original consumer purchaser" means the person who first purchased the product covered by this warranty other than for purpose of resale.

The warranty extends to and is enforceable by only the original consumer purchaser, and only for the period (during the applicable term) which the product remains in the possession of the original consumer purchaser. This warranty does not apply if it is found that at any time the equipment has not been used for its intended purpose.

For more information regarding this warranty, please contact your distributor.

WARNING! Any unauthorized changes or modifications to this unit without our prior written approval will void the user's warranty and will transfer health and safety obligations to the user.

WARNING! Changes or modifications to this unit not expressly approved by the party responsible for compliance could void the user's authority to operate the equipment.

NOTE: This equipment has been tested and found to comply with the limits for a class A digital device, pursuant to part 15 of the FCC rules. These limits are designed to provide reasonable protection against harmful interference when the equipment is operated in a commercial environment. This equipment generates uses and can radiate radio frequency energy and, if not installed and used in accordance with Owner's Manual, may cause harmful interference to radio communications. Operation of this equipment in a residential area is likely to cause harmful interference in a residential area is likely to cause harmful interference in which case the user will be required to correct the interference at his own expense.

SEAL CONTACT INFORMATION

©Copyright SEAL 2000, 2002

All rights are reserved. No part of the document may be photocopied, reproduced, or translated to another language without the prior written consent of SEAL .

The information contained in this document is subject to change without notice and should not be construed as a commitment by SEAL.

SEAL Graphics Americas

7091 Troy Hill Drive

Elkridge

MD 21075

U.S.A.

Tel: (410) 379 5400

Fax: (410) 379 8960

SEAL Graphics Uk Ltd

1 Watkins Close

Burnt Mills Industrial Estate

Basildon, Essex SS13 1BJ

England

Tel: +44 (0) 1268 530 331

Fax: +44 (0) 1268 725 864

SEAL Graphics Canada

1601 Matheson Blvd. E. Unit #4

Mississauga, Ontario

Canada, L4W 1H9

Tel: +1 905 212 9232 / 866

212 7325

Fax: +1 905 212 9313

SEAL assumes no responsibility for any errors that may appear in this document. Nor does it make expressed or implied warranty of any kind with regard to this material, including, but not limited to, the implied warranties of merchantability and fitness for a particular purpose.

SEAL shall not be liable for incidental or consequential damages in connection with, or arising out of the furnishing, performance, or use of this document and the program material which it describes.

SEAL Graphics Pacific Limited

Unit A, 13th Floor, Block1

Leader Industrial Centre

Tsuen Wan,

New Territories,

Hong Kong

Tel: +852 2407 3738

Fax: +852 2408 0973

SEAL Graphics Europe BV

Kanaaldijk O.Z. 3

P.O. Box 29

8100 AA Raalte

The Netherlands

Tel: +31 (0) 572 345 500

Fax: +31 (0) 572 345 501

Internet:

www.SEALBrands.com

Seal Brands ... the finishing touch.

The Information contained herein is general and does not constitute any warranties or guarantees